

Qumulo Hardware Servicing Guide



Copyright © 2026 Qumulo, Inc.

Table of Contents

Getting Started

Safety Recommendations.....	5
Identifying NICs and Choosing Transceivers and Cables.....	6
Creating a USB Drive Installer.....	10
Creating and Configuring a Cluster.....	13

Configuring Cluster Networking

Platforms with Unified Networking.....	15
Platforms with Split Networking.....	19

Configuring the Out-of-Band Management Port

Configuring iLO.....	23
Configuring IPMI.....	25

Replacing Hardware Components..... 26

C-192T, C-432T, and K-432T

Replacing the Chassis.....	28
----------------------------	----

Fsas Technologies PRIMERGY RX2540 M7

Racking Nodes.....	32
Configuring iRMC and Wiring Nodes.....	33
Creating and Configuring a Cluster.....	35
Drive Bay Mapping.....	37
Panel LEDs.....	39
Cluster Networking.....	40
Replacing Hardware Components.....	43

HPE Alletra 4110

Wiring Nodes and Networking a Cluster.....	47
Creating and Configuring a Cluster.....	51
Front and Internal Drives.....	55
Panel LEDs.....	57
Configuring iLO.....	60
Replacing Hardware Components.....	62

HPE Apollo 4200 Gen9

Wiring Nodes and Networking a Cluster	65
Creating and Configuring a Cluster	69
Front and Rear Drives.....	73
Panel LEDs.....	75
Drive LEDs.....	80
Configuring iLO.....	83
Replacing Hardware Components	85

HPE Apollo 4200 Gen10

Wiring Nodes and Networking a Cluster	88
Creating and Configuring a Cluster	91
Front and Rear Drives.....	95
Panel LEDs.....	97
Drive LEDs.....	102
Configuring iLO.....	105
Replacing Hardware Components	107

HPE Apollo 4200 Gen10 Plus

Wiring Nodes and Networking a Cluster	111
Creating and Configuring a Cluster	116
Front and Internal Drives.....	119
Panel LEDs.....	122
Configuring iLO.....	123
Replacing Hardware Components	125

HPE ProLiant DL325 Gen10 Plus

Wiring Nodes and Networking a Cluster	128
Creating and Configuring a Cluster	132
Front and Rear Drives.....	135
Configuring iLO.....	137
Replacing Hardware Components	139

Quiver 1U All-NVMe Gen1

Racking Nodes.....	142
Configuring IPMI and Wiring Nodes.....	143
Creating and Configuring a Cluster.....	145
Drive Bay Mapping.....	147
Panel LEDs.....	149
Cluster Networking.....	151
Replacing Hardware Components.....	157

Quiver 1U Hybrid Gen2

Racking Nodes.....	161
Configuring IPMI and Wiring Nodes.....	163
Creating and Configuring a Cluster.....	166
Drive Bay Mapping.....	169
Panel LEDs.....	171
Cluster Networking.....	172
Replacing Hardware Components.....	175

Quiver 2U Hybrid Gen2

Configuring IPMI and Wiring Nodes.....	185
Creating and Configuring a Cluster.....	188
Drive Bay Mapping.....	190
Panel LEDs.....	195
Cluster Networking.....	196
Replacing Hardware Components.....	199

Supermicro A+ ASG-1014S-ACR12N4H

Racking Nodes.....	202
Configuring IPMI and Wiring Nodes.....	203
Creating and Configuring a Cluster.....	205
Drive Bay Mapping.....	208
Panel LEDs.....	210
Cluster Networking.....	212
Replacing Hardware Components.....	215

Supermicro A+ WIO 1114S-WN10RT

Racking Nodes.....	219
Configuring IPMI and Wiring Nodes.....	222
Creating and Configuring a Cluster.....	224
Drive Bay Mapping.....	227
Panel LEDs.....	228
Cluster Networking.....	229
Replacing Hardware Components.....	232
Technical Specifications.....	239

Getting Started

Safety Recommendations

This section gives general safety recommendations.

⚠ Caution

Read these recommendations carefully. Failure to follow these recommendations can potentially cause damage to your equipment or injure the person who maintains it.

- **Operating Ambient Temperature:** When you install nodes in a closed or multi-unit rack assembly, the operating ambient temperature of the rack or cabinet environment can be greater than the ambient temperature of the room.

Install your equipment in an environment where the maximum ambient temperature (T_{ma}) doesn't exceed 40° C (104° F).

- **Sufficient Airflow:** Install your equipment in a way that avoids compromising the amount of airflow required for the equipment's safe operation.
- **Even Mechanical Loading:** Ensure your equipment is level when you mount it.
- **Circuit Load:** Determine the load your equipment can place on your supply circuit and refer to nameplate ratings to determine potential circuit overload scenarios.
- **Reliable Earthing:** Maintain earthing (by connecting to the part of the equipment that doesn't carry current).

Give particular attention to supply connections other than direct connections to the branch circuit (for example, power strips).

- **Redundant Power Supplies (PSU):** When you receive multiple PSUs with your equipment, connect each PSU to a separate circuit.
- **Equipment Under Maintenance:** Ensure that all equipment under maintenance has all of its PSUs disconnected.
- **Battery Replacement:** Use compatible battery types to avoid a potential explosion. Dispose of depleted batteries according to provided instructions.

Identifying NICs and Choosing Transceivers and Cables for Your Qumulo Node

This section explains how to identify the NICs in your nodes and choose the correct transceivers and cables.

Important

In April 2020, NVIDIA acquired Mellanox Technologies and began to use the name “NVIDIA ConnectX” for their NICs.

Step 1: Identify the NICs in Your Nodes

Most Qumulo-certified nodes are compatible with multiple NIC models. The NIC model determines transceiver compatibility.

1. Use SSH to connect to your node.
2. Run the `lspci | grep "Ethernet controller"` command.

Note

This command might return information about unused NICs that have interfaces with speeds of 10 Gbps (or slower).

A list of NICs appears. In the following example, we ran the command on a Supermicro 1114S node, which has two ConnectX-6 NICs.

```
45:00.0 Ethernet controller: Broadcom Inc. and subsidiaries BCM57416 NetXtrem
e-E Dual-Media 10G RDMA Ethernet Controller (rev 01)
45:00.1 Ethernet controller: Broadcom Inc. and subsidiaries BCM57416 NetXtrem
e-E Dual-Media 10G RDMA Ethernet Controller (rev 01)
81:00.0 Ethernet controller: Mellanox Technologies MT28908 Family [ConnectX-6]
81:00.1 Ethernet controller: Mellanox Technologies MT28908 Family [ConnectX-6]
c5:00.0 Ethernet controller: Mellanox Technologies MT28908 Family [ConnectX-6]
c5:00.1 Ethernet controller: Mellanox Technologies MT28908 Family [ConnectX-6]
```

3. To determine the speed and firmware compatibility information for the NICs in your node, refer to the following table.

NIC Model	Speed	Firmware Compatibility Information
82599ES	10 Gbps	Intel 82599ES 10 Gigabit Ethernet Controller
AOC-S100G-b2C	100 Gbps	<ul style="list-style-type: none"> • Supermicro Networking Cables and Transceivers Compatibility Matrix • Broadcom Optical Transceivers • Supported Cables for Broadcom Ethernet Network Adapters in the Broadcom Ethernet Network Adapter User Guide
AOC-S25G-b2S	25 Gbps	
ConnectX-3	10 Gbps	Supported Cables and Modules in the NVIDIA ConnectX-3 Firmware Release Notes
ConnectX-3 Pro	40 Gbps	Supported Cables and Modules in the NVIDIA ConnectX-3 Pro Firmware Release Notes
ConnectX-4	40 Gbps	Firmware Compatible Products in the NVIDIA Mellanox ConnectX-4 Adapter Cards Firmware Release Notes
ConnectX-4 Lx	25 Gbps	Firmware Compatible Products in the NVIDIA ConnectX-4 Lx Adapter Cards Firmware Release Notes
ConnectX-5	100 Gbps	Firmware Compatible Products in the NVIDIA ConnectX-5 Adapter Cards Firmware Release Notes
ConnectX-6	100 Gbps	Firmware Compatible Products in the NVIDIA ConnectX-6 Adapter Cards Firmware Release Notes
ConnectX-6 Dx	100 Gbps	Firmware Compatible Products in the NVIDIA ConnectX-6 Dx Adapter Cards Firmware Release Notes
E810-CQDA2	100 Gbps	Intel Ethernet Network Adapter E810-2CQDA2 <div style="border: 1px solid #add8e6; padding: 10px; margin-top: 10px;"> <p>Note Intel might support, but doesn't verify, third-party transceiver compatibility.</p> </div>

NIC Model	Speed	Firmware Compatibility Information
E810-XXVDA2	25 Gbps	Intel Ethernet Network Adapter E810-XXVDA2 <div style="border: 1px solid #add8e6; padding: 10px; margin-top: 10px;"> <p>Note Intel might support, but doesn't verify, third-party transceiver compatibility.</p> </div>
P2100G	100 Gbps	<ul style="list-style-type: none"> • Broadcom Optical Transceivers • Supported Cables for Broadcom Ethernet Network Adapters in the Broadcom Ethernet Network Adapter User Guide
P225P	25 Gbps	

Step 2: Choose Transceivers for Your Nodes

This section lists and explains the differences between the types of transceivers available for your nodes.

- **Lucent Connector (LC):** The LC with two fibers is very common for 10 Gbps and 25 Gbps connections.

Note

Although there are transceivers that can use LC fiber optic cables for 40 Gbps and 100 Gbps connections, these transceivers are generally more expensive, consume more power, and are mainly intended for reusing LC cabling, or for long-distance applications.

- **Lucent Connector Duplex (LC Duplex):** The LC duplex with two fibers is the most common standard for 25 Gbps connections. The maximum short-range connection is 100 m and long-range connection is 10 km. There is also an extended-range standard with a maximum of 40 km.
- **Multi-Fiber Push On (MPO):** The MPO connector with eight fibers is a common connector for 40 Gbps connections.
- **PAM4:** Some newer switches can establish 100 Gbps connections by using double 50 Gbps PAM4 connections instead of the more common four 25 Gbps connections. For information about configuring Pulse Amplitude Modulation 4-level (PAM4), see [Auto-Negotiation on Ethernet NIC Controllers](#) in the Broadcom documentation.

- **SR4:** The SR4, with four QSFP28 connections over an eight-fiber cable, is the most common and cost-efficient standard for 100 Gbps connections. The maximum range for SR4 is 100 m.

Step 3: Choose Cables for Your Transceivers

This section lists and explains the differences between the types of cables available for your transceivers.

i Note

If you use DAC or AOC cables, ensure that the manufacturers of your NIC and network switch both support your cables.

- **Optical Cables:** We recommend using optical cables and optical transceivers that both the NIC and the switch support.
- **Direct Attach Cables (DACs):** Although these cables are significantly cheaper than optical cables and are less prone to compatibility and thermal issues, they are limited in length (2-3 m, up to 5 m maximum).
- **Active Optical Cables (AOCs):** Although these cables are cheaper than dedicated transceivers and fiber optic cables, they might cause compatibility issues, or your NIC or switch might not support them.

Creating a Qumulo Core USB Drive Installer

This section explains how to create a Qumulo Core USB Drive Installer on macOS or Windows.

How is the Qumulo Core Product Package Different from the Qumulo USB Installer?

Whereas the Qumulo USB Installer is designed for specific models of third-party hardware bundled with Qumulo Core, the Qumulo Core Product Package is designed for installation on your own hardware.

Because Qumulo has no control over the host operating system (OS), the following are the main differences in functionality between the two.

- **Web UI:** The Qumulo Core Product Package has no kiosk mode. The Qumulo Core Web UI runs directly on your node.
- **Well-Known `admin` User:** When you use the Qumulo Core Product Package, changing the `admin` user's password has no effect on the host OS. You must create your own users on the host OS.
- **Automatic SSH Configuration:** Any SSH configuration set by using `multitenancy` REST APIs have no effect on the host OS. You must configure SSH on the host OS.
- **System Partitions and Directories:** The Qumulo Core Product Package has no `/config` partition for storing logs and container images or `/history` partitions for storing configuration files.
The Qumulo Core container stores logs and container images in the `/var/opt/qumulo/history` directory and configuration files in the `/etc/qumulo` directory. You can also configure your own mounts and partitions on the host OS.
- **Core Dump Handler:** You must configure the core dump handler on the host OS. For more information, see [core Linux Manual Page](#).

For more information, see [Installing the Qumulo Core Product Package](#) in the Qumulo On-Premises Administrator Guide.

Prerequisites

- USB 3.0 (or higher) drive (8 GB minimum)
- Qumulo Core USB installer image (to get the image, [contact the Qumulo Care Team](#))

To Create a USB Drive Installer on macOS

1. Open Terminal and log in as `root` by using the `sudo -s` command.
2. Insert your USB drive and then find its disk label by using the `diskutil list` command.

In the following example, the USB drive's device label is `disk2`.

```
/dev/disk2 (external, physical):  
#:                TYPE NAME                SIZE      IDENTIFIER  
0:                Windows_FAT_32 MY_USB_DRIVE  *32.0 GB  disk2
```

3. To unmount the USB drive, use your USB drive's device label. For example:

```
diskutil unmountDisk /dev/disk2
```

4. To write the Qumulo Core USB installer image to your USB drive, specify the path to your image file and the USB drive's device label. For example:

```
dd if=/path-to-image-file/ of=/dev/rdisk2 bs=2m
```

Note

If you encounter an `Operation not permitted` error in macOS, take the following steps:

- a. Navigate to `System Preferences > Security & Privacy`.
- b. On the `Privacy` tab, grant `Full Disk Access` to Terminal.
- c. Restart Terminal and try the command again.
- d. When finished, remove `Full Disk Access` from Terminal.

5. Eject your Qumulo Core USB Drive Installer. For example:

```
diskutil eject disk2
```

To Create a USB Drive Installer on Windows

To create a USB Drive Installer on Windows, you must use a third-party application such as [Rufus](#). We recommend Rufus because it can detect many USB storage devices (rather than only Windows-compatible ones).

Important

- We don't recommend using other tools (such as Win32 Disk Imager) because they might encounter errors when unable to recognize the USB drive after writing data to it.
- When the operation concludes, you might not be able to view the contents of the USB drive on Windows because the drive will be formatted by using a different file system.

1. Insert your USB drive and run Rufus.

Tip

A 32 GB or 64 GB USB drive is suitable for the USB Drive Installer.

2. Under **Drive Properties**, select a device and the path to the Qumulo Core USB installer image.
3. For **Partition scheme**, select **MBR** and for **Target System**, select **BIOS** or **UEFI**.
4. Under **Format Options**, ensure that the **File system** is set to **NTFS**.
5. Click **Start**.
6. If prompted to download a new version of **GRUB** or **vesamenu.c32**, click **No**.
7. When the **ISOHybrid image detected** dialog box appears, click **Write in DD Image mode** and then click **OK**.

Important

For this operation to succeed, you must use DD Image mode.

8. To confirm the operation, destroy all data on the USB drive, and image the drive click **OK**.

Creating and Configuring a Qumulo Cluster with Your Nodes

This section explains how to prepare your platform nodes for creating a Qumulo cluster.

Step 1: Boot by Using the Qumulo Core USB Drive Installer

1. Insert a USB drive with the [Qumulo Core installer \(page 10\)](#) into an available port and power on the node.
2. When the node begins to boot, enter the boot menu.

Note

The boot setting is persistent: When you boot from a USB drive once, the node continues to boot from the USB drive. After you finish installing Qumulo Core, remove the USB drive from the node.

3. On the boot drive selection screen, select your USB drive (usually labeled with **UEFI OS**) and boot into it.

The Qumulo Core installation begins.

Step 2: Create and Configure Your Cluster

1. Review the End User Agreement, click **I agree to the End User Agreement**, and then click **Submit**.
2. Name your cluster.
3. On the **1. Set up cluster** page, select the nodes to add to your cluster.

As you select nodes, the installer updates the total capacity of your cluster at the bottom of the page.

Note

If any nodes are missing, confirm that they are powered on and connected to the same network.

4. Confirm that the individual nodes have the expected capacity.
5. On the **2. Confirm cluster protection level** page, Qumulo Core selects the recommended 2-, 3-, or 4-drive protection level based on your cluster size and node type.
6. If the **Customize Protection Level** option appears, you can increase your system resilience by selecting 3- or 4-drive protection.

⚠ Important

- Qumulo Core 6.1.0.1 and 6.1.1 support Adaptive Data Protection by letting you reconfigure your cluster's fault tolerance level and storage efficiency only when you add nodes to your cluster.

Depending on your cluster, Qumulo Core shows configuration options that offer better fault tolerance levels, better storage efficiency, or both benefits. To enable Adaptive Data Protection for your cluster, you must [contact the Qumulo Care Team](#).

- In Qumulo Core 6.1.2 (and higher), you can change your cluster's data protection configuration when you add or replace nodes by using the qq CLI.
- Using 3- or 4-drive protection reduces the total capacity of your cluster.

7. Enter a password for the administrative account and click **Create Cluster**.
8. To access the Qumulo Core Web UI, connect to any node by entering its IP address into a browser.

Configuring Cluster Networking

Networking a Qumulo Cluster with a Unified Networking Configuration

This section explains how to network a cluster with platforms that use a unified networking configuration.

✓ Tip

To identify the eth port, run the following command:

```
for i in /sys/class/net/eth*; \
do echo $i; \
cat $i/device/uevent | \
grep -i pci_slot; \
done
```

Prerequisites

ⓘ Note

Before you create your Qumulo cluster, if your client environment requires Jumbo Frames (9,000 MTU), configure your switch to support a higher MTU.

Your node requires the following resources.

- A network switch with the following specifications:
 - Ethernet connectivity
 - Fully non-blocking architecture
 - IPv6 capability
- Compatible networking cables
- A sufficient number of ports for connecting all nodes to the same switch fabric
- One static IP for each node, for each defined VLAN

Recommended Configuration

This platform uses a *unified networking configuration* in which the same NIC handles back-end and front-end traffic. In this configuration, each networking port provides communication with clients and between nodes. You can connect the NIC's ports to the same switch or to different switches. However, for greater reliability, we recommend connecting both ports on every node to each switch.

We recommend the following configuration for your node.

- Your Qumulo MTU configured to match your client environment
- Two physical connections for each node, one connection for each redundant switch
- One Link Aggregation Control Protocol (LACP) port-channel for each network on each node, with the following configuration
 - Active mode
 - Slow transmit rate
 - Access port or trunk port with a native VLAN
- DNS servers
- A Network Time Protocol (NTP) server
- Firewall protocols or ports allowed for proactive monitoring
- Where **N** is the number of nodes, **N-1** floating IP addresses for each node, for each client-facing VLAN

Connecting to Redundant Switches

For redundancy, we recommend connecting your cluster to dual switches. If either switch becomes inoperative, the cluster is still be accessible from the remaining switch.

- Connect the two NIC ports on your nodes to separate switches.
- The uplinks to the client network must equal the bandwidth from the cluster to the switch.
- The two ports form an LACP port channel by using a multi-chassis link aggregation group.
- Use an appropriate inter-switch link or virtual port channel.

Connecting to a Single Switch

You can connect a your cluster to a single switch. If this switch becomes inoperative, the entire cluster becomes inaccessible.

- Connect the two NIC ports on your nodes to a single switch.

- The uplinks to the client network must equal the bandwidth from the cluster to the switch.
- The two ports form an LACP port channel.

Four-Node Cluster Architecture Diagram

The following is the recommended configuration for a four-node cluster connected to an out-of-band management switch and redundant switches.

Management LAN Ports
Connect to Out-of-Band
Management Switch

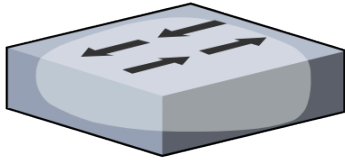

Out-of-Band
Management Switch

Ports Acting as Front-End and Back-End
Connect to Redundant Switches

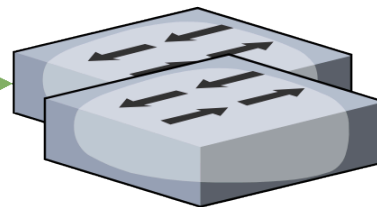
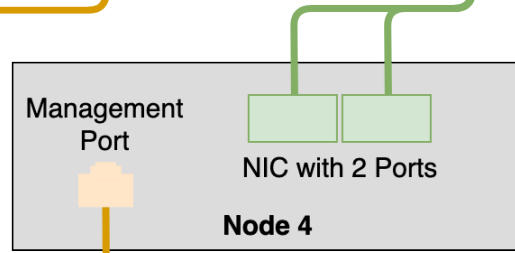
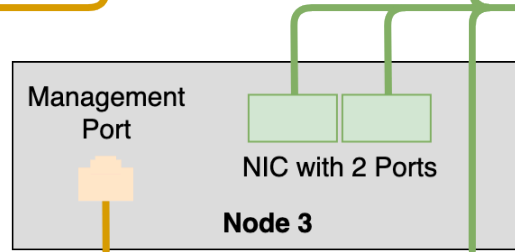
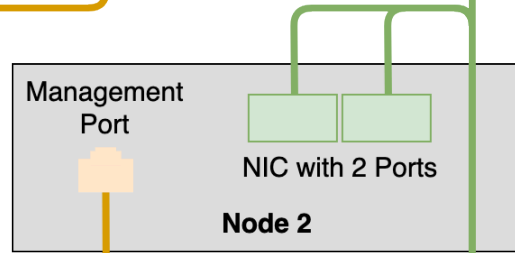
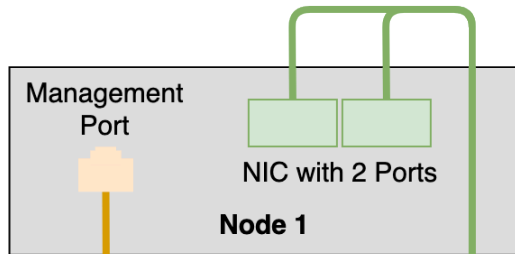

Redundant Switches
Connect to Local Network
and Connect Nodes Together

Networking a Qumulo Cluster with a Split Networking Configuration

This section explains how to network a cluster with platforms that use a split networking configuration.

✓ Tip

To identify the eth port, run the following command:

```
for i in /sys/class/net/eth*; \  
do echo $i; \  
cat $i/device/uevent | \  
grep -i pci_slot; \  
done
```

Prerequisites

i Note

Before you create your Qumulo cluster, if your client environment requires Jumbo Frames (9,000 MTU), configure your switch to support a higher MTU.

Your node requires the following resources.

- A network switch with the following specifications:
 - Ethernet connection
 - Fully non-blocking architecture
 - IPv6 capability
- Compatible networking cables
- A sufficient number of ports for connecting all nodes to the same switch fabric
- One static IP for each node, for each defined VLAN

Recommended Configuration

⚠ Important

We don't recommend connecting to a single back-end NIC port because the node becomes unavailable if the single connection fails.

This platform uses a *split networking configuration* in which different NICs handle back-end and front-end traffic. You can connect the front-end and back-end NICs to the same switch or to different switches. However, for greater reliability, we recommend connecting all four ports on every node: Connect both front-end NIC ports to the front-end switch and both back-end NIC ports to the back-end switch.

We recommend the following configuration for your node.

- Your Qumulo front-end MTU configured to match your client environment
- One set of redundant switches for the back-end network (9,000 MTU minimum)

📘 Note

You can configure front-end and back-end traffic on the same switch.

- One physical connection for each node, for each redundant switch
- One Link Aggregation Control Protocol (LACP) port-channel for each network (front-end and back-end) on each node, with the following configuration
 - Active mode
 - Slow transmit
 - Access port or trunk port with a native VLAN
- DNS servers
- A Network Time Protocol (NTP) server
- Firewall protocols or ports allowed for proactive monitoring
- Where **N** is the number of nodes, **N-1** floating IP addresses for each node, for each client-facing VLAN

Connecting to Redundant Switches

For redundancy, we recommend connecting your cluster to dual switches. If either switch becomes inoperative, the cluster is still be accessible from the remaining switch.

- **Front End**
 - Connect the two front-end NIC ports on your nodes to separate switches.

- The uplinks to the client network must equal the bandwidth from the cluster to the switch.
- The two ports form an LACP port channel by using a multi-chassis link aggregation group.
- **Back End**
 - Connect the two back-end NIC ports on your nodes to separate switches.
 - Use an appropriate inter-switch link or virtual port channel.
- **Link Aggregation Control Protocol (LACP)**
 - For all connection speeds, the default behavior is that of an LACP with 1,500 MTU for the front-end and 9,000 MTU for the back-end interfaces.

Connecting to a Single Switch

You can connect your cluster to a single switch. If this switch becomes inoperative, the entire cluster becomes inaccessible.

- **Front End**
 - Connect the two front-end NIC ports to a single switch.
 - The uplinks to the client network must equal the bandwidth from the cluster to the switch.
 - The two ports form an LACP port channel.
- **Back End**
 - Connect the two band-end ports to a single switch.
- **Link Aggregation Control Protocol (LACP)**
 - For all connection speeds, the default behavior is that of an LACP with 1,500 MTU for the front-end and 9,000 MTU for the back-end interfaces.

Four-Node Cluster Architecture Diagram

The following is the recommended configuration for a four-node cluster connected to an out-of-band management switch and redundant switches.

Management LAN Ports
Connect to Out-of-Band
Management Switch

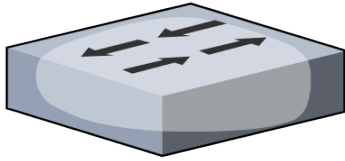

Out-of-Band
Management Switch

Front-End and Back-End Ports
Connect to Redundant Switches

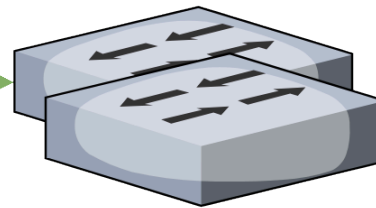
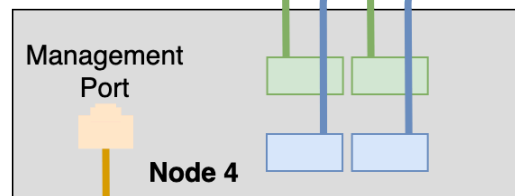
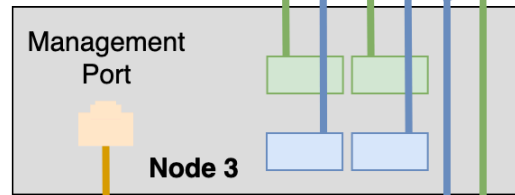
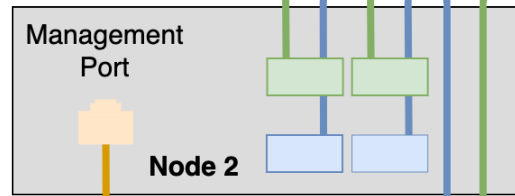
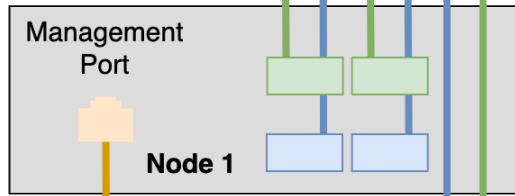

Front-End Redundant Switches
Connect to Local Network

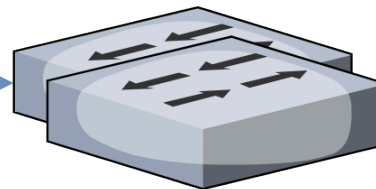

Back-End Redundant Switches
Connect Nodes Together

Configuring the Out-of-Band Management Port

Configuring the Integrated Lights Out (iLO) Port

This section explains how to configure the out-of-band management port on platforms that use the Integrated Lights Out (iLO) interface.

Prerequisites

To configure the iLO port, you must have root access to the client-facing network through SSH. For example, you can run the `sudo -s` command.

Important

Access to the iLO port on a public LAN can have serious security implications because it can grant anyone with credentials direct access to your server's hardware and console. Follow security best practices when implementing iLO access.

How the iLO Port Works

Your node provides iLO support for out-of-band maintenance access even when the node is plugged in but powered off.

The iLO port is located on the rear of the node. For more information, see the documentation from your hardware vendor.

Your nodes receive DHCP address assignments by default. When you configure a node's iLO port, you can access the node by using the IP address (that the DHCP server assigns to the node) and a browser that supports HTML5, Java, or .NET.

Important

We strongly recommend separating your iLO access network from your client-facing network.

To access iLO configuration from the BIOS System Utilities menu, press F9.

Note

The IMPI username and password are unrelated to your Qumulo administrative credentials.

iLO Configuration

To configure the iLO port, you must use `ipmitool`. For more information, see the following HPE resources:

- [HPE iLO 6 User Guide](#)
- [HPE iLO IPMI User Guide](#)

Configuring the Intelligent Platform Management Interface (IPMI) Port

This section explains how to configure the out-of-band management port on platforms that use the Intelligent Platform Management Interface (IPMI).

How the IPMI Port Works

The dedicated out-of-band management port allows functionality such as remote display, control, and power. The port uses the Intelligent Platform Management Interface (IPMI) protocol.

The IPMI port is located on the back of your node. For more information, see the documentation from your hardware vendor.

For more information, see [Default IPMI Usernames and Passwords](#)  on Qumulo Care.

Note

The IPMI username and password are unrelated to your Qumulo administrative credentials.

IPMI Configuration

For information about configuring the IPMI port, see the documentation from your hardware vendor.

Replacing Hardware Components in Your Nodes

This section explains how to replace hardware components in your platform's nodes.

For detailed instructions, see the documentation from your hardware vendor.

To Locate a Failed Drive by using the Qumulo Core Web UI

1. Log in to Qumulo Core.
2. Click **Cluster > Overview** and then click the name of the node with a failed drive.
3. On the page for the node, under **Drive Details**, the serial number for the failed drive is listed.
4. Use the failed drive's serial number and a server management tool to determine the physical location of the failed drive.

Initializing a Replacement Boot Drive

After you replace the boot drive, you must initialize the replacement boot drive by using the Qumulo Core Installer and then rebuild the replacement boot drive by using a script on the node in your cluster.

Step 1: Initialize the Replacement Boot Drive

Tip

To get the correct version of the Qumulo Core Installer for the node in your cluster, [contact the Qumulo Care Team](#)

1. [Create a Qumulo Core USB Drive Installer \(page 0\)](#).
2. Power on your node, enter the boot menu, and select your USB drive.

The Qumulo Core Installer begins to run automatically.

3. When prompted, take the following steps:
 - a. Select `[x] Perform maintenance`.
 - b. Select `[1] Boot drive reset` and then follow the prompts.

The Qumulo Core Installer initializes the boot drive.

4. When the process is complete, the node is powered down automatically.

Step 2: Rebuild the Replacement Boot Drive

1. Power on your node and log in to the node by using the `qq` CLI.

2. To get `root` privileges, run the `sudo qsh` command.
3. To stop the Qumulo Networking Services, run the `service qumulo-networking stop` command.
4. To configure the IP address for the node, run the `ip addr add` command and specify the node's IP address. For example:

```
ip addr add 203.0.113.0/CDR dev bond0
```

5. Ensure that the node can ping other nodes in the cluster.
6. Run the `rebuild_boot_drive.py` script and specify the IP address of *another node* in the cluster, the ID of the node whose boot drive has been replaced, and the password of the administrative account of the cluster. For example:

Note

If your password includes special characters such as the parenthesis (()) or the asterisk (*), use the backslash (\) to escape these characters.

```
/opt/qumulo/rebuild_boot_drive.py \  
  --address 203.0.113.1 \  
  --node-id 2 \  
  --username admin \  
  --password my\ (Special\ *Password
```

Follow the prompts.

7. When the process is complete, reboot the node.

C-192T, C-432T, and K-432T

Replacing the Chassis in Your C-192T, C-432T, and K-432T Nodes

This section explains how to replace the chassis in C-192T, C-432T, and K-432T nodes.

⚠ Important

- The C-192T, C-432T, and K-432T platforms will reach their End of Platform Support (EoPS) on May 9, 2030.
- We strongly recommend having another person help you with this process.

Step 1: Prepare for Chassis Replacement

1. To shut down the node, use the power button at the front of the node.

Alternatively, connect to the node by using SSH and run the `sudo shutdown -h now` command.

2. Disconnect all cables from the back of the node.
3. To pull the node out from the rack, release the small, white tabs on the rails that hold the chassis in place.
4. Place the node on a flat surface.
5. To release the lid, remove the small screw on the upper-right side of the node (viewed from the rear).
6. Press the large **PUSH** button on each side of the chassis frame.



The inner components of the node are exposed.

Step 2: Replace the M.2 Boot Drive, NVMe SSDs, and HDDs

1. Remove the internal M.2 boot drive and then transfer it into the replacement chassis Qumulo provided to you.

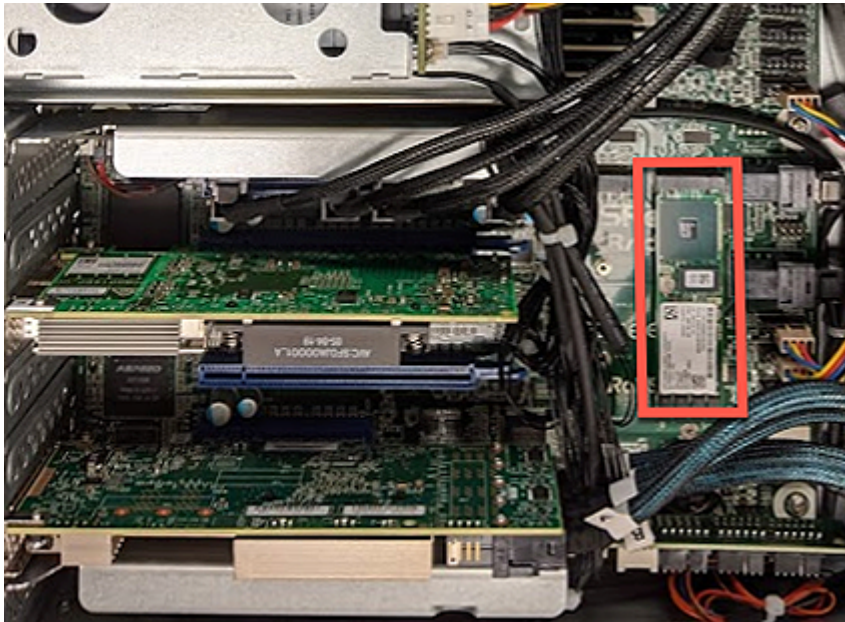

2. Remove the rear NVMe SSDs and then transfer them into the replacement chassis. The following is the mapping for the drives.

6	4	2
5	3	1

Note

To allow the front HDD trays to slide open, remove any shipping screws from the replacement chassis.



3. Install the replacement chassis in an appropriate location in your server rack.
4. Starting with the top drawer, transfer the HDDs from each tray in the original chassis into a corresponding bay in the replacement chassis. For more information about drive bays, see [C-Series Drive Diagrams](#) on Qumulo Care.

Important

Work on one drawer at a time. If you apply 2 kg (or more) of downward force to a drawer, it might deform while opened.

- a. To open the HDD drawer, use the blue lever at the front of the node.
- b. To remove an HDD from the original chassis, gently lift up the drive tray knob. This lets the drive move forward and unlatch.



- c. To insert an HDD into the replacement chassis, gently slide the drive tray knob backwards. This latches the drive and knob in place.
- d. Reconnect the cables to the HDDs, making sure that you reseat both ends of the cable.

Note

- The HDD carriers in the top and middle trays connect to an HBA controller card at the rear of the chassis.
- The HDD carriers in the the bottom tray connect directly to the motherboard at the rear of the chassis.

5. Reconnect the power and networking cables to the node.

6. Power on the node.

Step 3: (Optional) Reconfiguring the Out-of-Band Management (IPMI) Settings

If the current IPMI settings for your node are configured statically (rather than by using DHCP), you must reapply the static IPMI settings to the replacement node. For more information, see [IPMI Quick Reference Guide for Qumulo C-Series](#) on Qumulo Care.

For more information, see [Default IPMI Usernames and Passwords](#)  on Qumulo Care.

Fsas Technologies PRIMERGY RX2540 M7

Racking Your Fsas Technologies PRIMERGY RX2540 M7 Nodes

This section explains how to rack Fsas Technologies RX2540 M7 nodes in a data center.

To Install the Rails in the Server Rack

Fsas Technologies RX2540 M7 uses Rack Mount Kit QRL with CMA (PYBRR0B). Follow the instructions in the [Fsas Technologies Rail Kit—Ball Bearing Type \(For Drop In / Slide In\)](#)  manual.

To Insert the Chassis into the Server Rack

Follow the instructions in the Fsas Technologies Upgrade and Maintenance Manual: [Installing the server in the rack \(p. 61\)](#) .

To Remove the Chassis from the Server Rack

Follow the instructions in the Fsas Technologies Upgrade and Maintenance Manual: [Removing the server from the rack \(p. 56\)](#) .

Configuring the Integrated Remote Management Controller (iRMC) and Wiring Your Fsas Technologies PRIMERGY RX2540 M7 Nodes

This section explains how to wire the out-of-band management (iRMC) port, 25 Gbps ports, and power on Fsas Technologies RX2540 M7 nodes.

This platform uses a *unified networking configuration* in which the same NIC handles back-end and front-end traffic. In this configuration, each networking port provides communication with clients and between nodes. You can connect the NIC's ports to the same switch or to different switches.

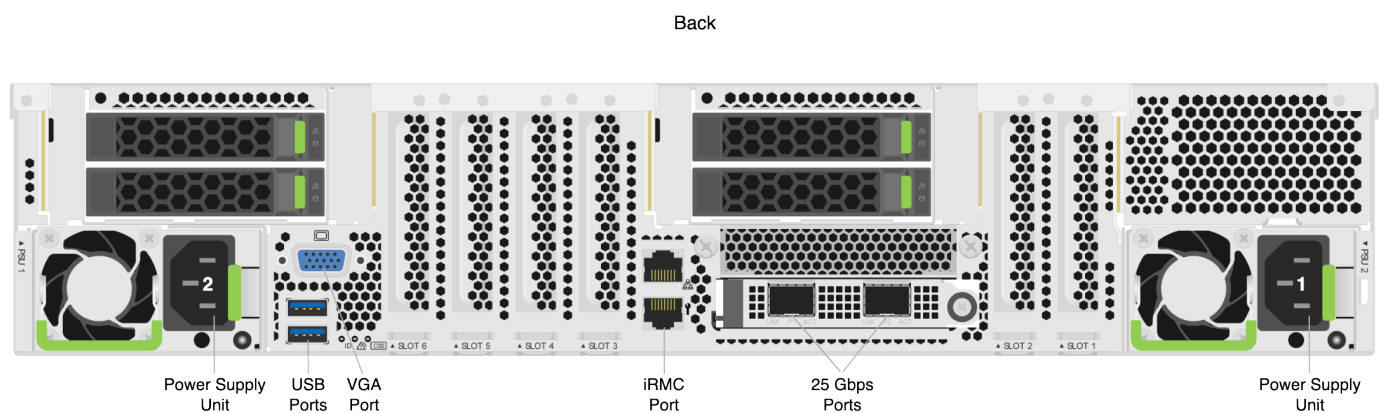

Step 1: Connecting the Out-of-Band Management (iRMC) Port

The dedicated out-of-band management port allows functionality such as remote display, control, and power. The port uses the Integrated Remote Management Controller (iRMC) protocol. Connect the iRMC port first on the back of your node (the bottom Ethernet port).

⚠ Important

The iRMC username and password are unrelated to your Qumulo administrative credentials.

To configure the iRMC port, you must use Fsas Technologies ServerView. For more information, see [Logging on to the iRMC S6 for the first time \(p. 30\)](#) and [iRMC factory defaults \(p. 31\)](#) in the Fsas Technologies iRMC S6 Configuration and Maintenance Manual.

Step 2: Connecting the 25 Gbps Ports

After you connect the iRMC port, connect your 25 Gbps ports (compatible with SFP28). There are two 25 Gbps ports on the back of your node. This platform uses a *unified networking configuration* in which the same NIC handles back-end and front-end traffic. In this configuration, each networking port provides communication with clients and between nodes. You can connect the NIC's ports to the same switch or to different switches.

✓ Tip

To identify the eth port, run the following command:

```
for i in /sys/class/net/eth*; \  
do echo $i; \  
cat $i/device/uevent | \  
grep -i pci_slot; \  
done
```

Step 3: Connecting the Power

After you connect your 25 Gbps ports, connect power to the node. There are two power sockets on the back of your node. To maximize redundancy, connect each PSU to a separate power supply or power distribution unit (PDU).

Creating and Configuring a Qumulo Cluster with Fsas Technologies PRIMERGY RX2540 M7 Nodes

This section explains how to prepare Fsas Technologies RX2540 M7 nodes for creating a Qumulo cluster.

Important

Your Fsas Technologies RX2540 M7 node might require a firmware update. Before you get started with Qumulo Core, contact [Fsas Technologies Product Support](#) for information about the minimum required firmware level and hardware configuration.

Step 1: Verify Your Node

1. Shut down your node and connect a display, a keyboard, and a mouse to it.
2. Plug the [Qumulo Core USB Drive Installer](#) into an available USB port on the node and then press the power button.

Step 2: Boot by Using the Qumulo Core USB Drive Installer

1. When the node powers on and begins to boot, on the Fsas Technologies screen, press F12.

Note

The boot setting is persistent: When you boot from a USB drive once, the node continues to boot from the USB drive. After you finish installing Qumulo Core, remove the USB drive from the node.

2. On the **Please select boot device:** screen, select your USB drive (usually labeled with **UEFI OS**) and boot into it.
3. On the GRUB menu, select your USB drive.

Step 3: Create and Configure Your Cluster

The Qumulo Installer runs automatically.

1. Review the **End User Agreement**, click **I agree to the End User Agreement**, and then click **Submit**.
2. Name your cluster.
3. On the **1. Set up cluster** page, select the nodes to add to your cluster.

As you select nodes, the installer updates the total capacity of your cluster at the bottom of the page.

Note

If any nodes are missing, confirm that they are powered on and connected to the same network.

4. Confirm that the individual nodes have the expected capacity.
5. On the **2. Confirm cluster protection level** page, Qumulo Core selects the recommended 2, 3, or 4-drive protection level based on your cluster size and node type.
6. If the **Customize Protection Level** option appears, you can increase your system resilience by selecting 3- or 4-drive protection.

Important

- Qumulo Core 6.1.0.1 and 6.1.1 support Adaptive Data Protection by letting you reconfigure your cluster's fault tolerance level and storage efficiency only when you add nodes to your cluster.

Depending on your cluster, Qumulo Core shows configuration options that offer better fault tolerance levels, better storage efficiency, or both benefits. To enable Adaptive Data Protection for your cluster, you must [contact the Qumulo Care Team](#).

- In Qumulo Core 6.1.2 (and higher), you can change your cluster's data protection configuration when you add or replace nodes by using the `qq` CLI.
- Using 3- or 4-drive protection reduces the total capacity of your cluster.

7. Enter a password for the administrative account and click **Create Cluster**.
8. To access the Qumulo Core Web UI, connect to any node by entering its IP address into a browser.

Drive Bay Mapping in Fsas Technologies PRIMERGY RX2540 M7 Nodes

This section explains the drive bay mapping in Fsas Technologies RX2540 M7 nodes.

Your Fsas Technologies RX2540 M7 chassis contains 12 or 8 HDDs in the front, 4 NVMe drives in the back, and 2 mirrored NVMe boot drives in internal M.2 expansion slots. The following is the mapping for the drives.

Note

To determine the drive configuration for your node, see [Technical Specifications \(page 0\)](#).

Front HDD Drives

For more information, see [To Replace an HDD \(page 45\)](#).

48TB and 144TB Nodes

In [48TB and 144TB Nodes \(page 0\)](#), all drive bays are populated.

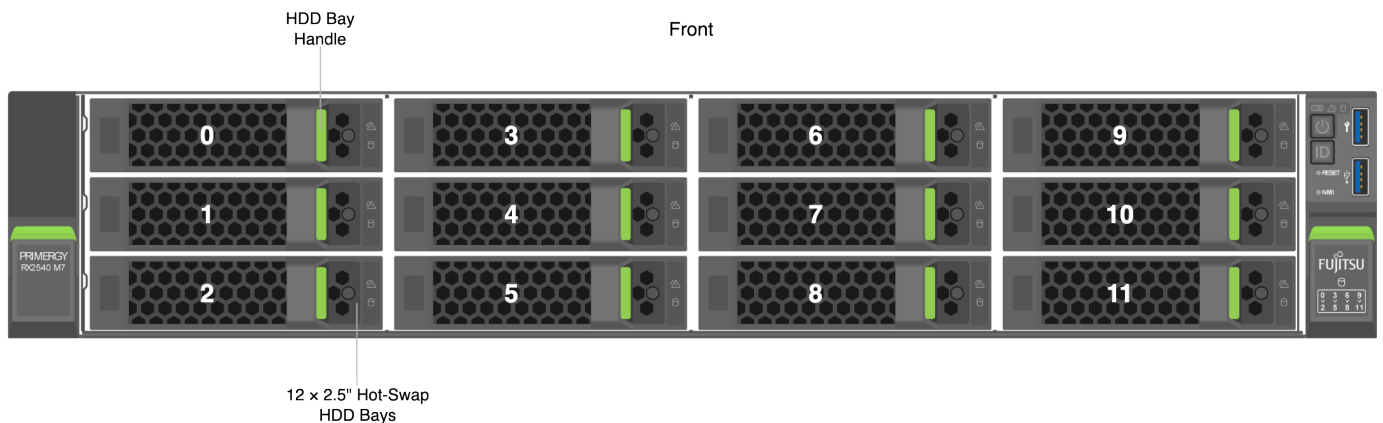

96TB Nodes

In [96TB Nodes \(page 0\)](#), some drive bays are empty.

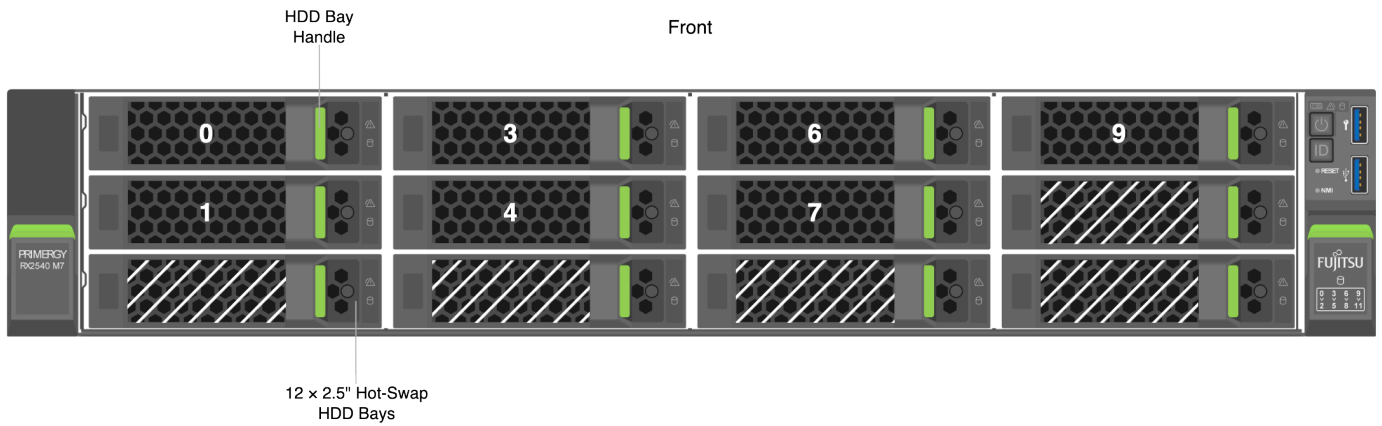

Back NVMe Drives

For more information, see [To Replace an NVMe Drive \(page 46\)](#).

Note

Because the expansion bays are universal, your node might contain labels such as HDD0 for the NVMe slots.

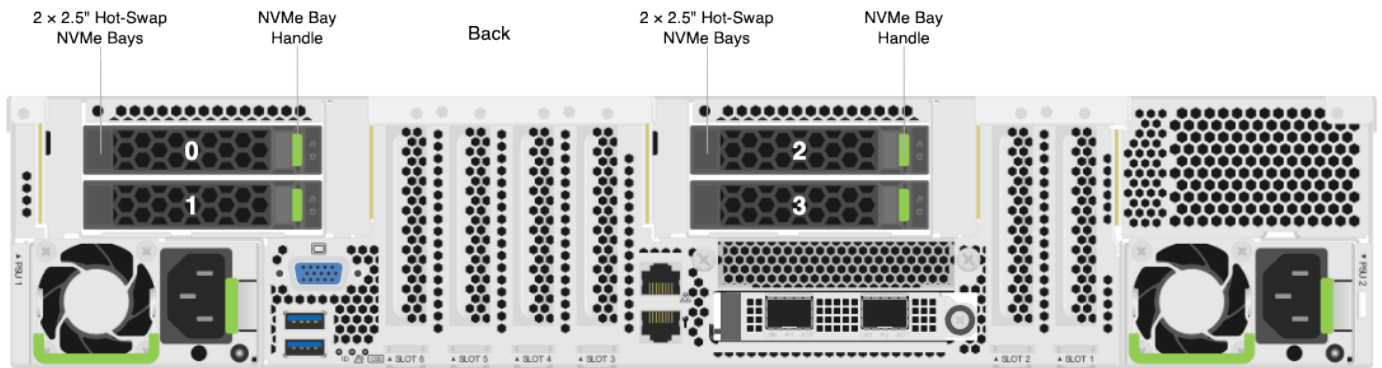

Internal NVMe M.2 Boot Drive

The boot drives are located at the M.2 expansion slot on an interposer (controller) board. For more information, see [To Replace an NVMe M.2 Boot Drive \(page 44\)](#).

Follow the instructions in the Fsas Technologies Upgrade and Maintenance Manual: [Slots for M.2 SSDs on the M.2 interposer board \(p. 211\)](#).

Panel LEDs on Fsas Technologies PRIMERGY RX2540 M7 Nodes

This section explains the LEDs on Fsas Technologies RX2540 M7 nodes.

Front Panel LEDs and Buttons

On the front, right side of your node, there are five LEDs.

Label	Color
CSS (Customer Self Service) LED	● (orange)
Global Error LED	● (orange)
Drive Access LED	● (green)
Power Button with LED (DC On)	● (green)
Power Button with LED (AC On)	● (white)
Identification Button with LED	● (blue)

Rear Panel LEDs

On the rear, left side of your node, there are three LEDs.

Label	Color
Identification LED	● (blue)
Global Error LED	● (orange)
CSS (Customer Self Service) LED	● (orange)

Front HDD and Rear NVMe Carrier LEDs

Each HDD drive carrier in the front and NVMe carrier in the back has two LEDs.

Label	Color
Drive Error	● (orange)
Drive Access	● (green)

Networking Your Fsas Technologies PRIMERGY RX2540 M7 Cluster

This section explains how to network a Fsas Technologies PRIMERGY RX2540 M7 cluster.

✓ Tip

To identify the eth port, run the following command:

```
for i in /sys/class/net/eth*; \  
do echo $i; \  
cat $i/device/uevent | \  
grep -i pci_slot; \  
done
```

Prerequisites

ⓘ Note

Before you create your Qumulo cluster, if your client environment requires Jumbo Frames (9,000 MTU), configure your switch to support a higher MTU.

Your node requires the following resources.

- A network switch with the following specifications:
 - Ethernet connectivity
 - Fully non-blocking architecture
 - IPv6 capability
- Compatible networking cables
- A sufficient number of ports for connecting all nodes to the same switch fabric
- One static IP for each node, for each defined VLAN

Recommended Configuration

This platform uses a *unified networking configuration* in which the same NIC handles back-end and front-end traffic. In this configuration, each networking port provides communication with clients and between nodes. You can connect the NIC's ports to the same switch or to different switches. However, for greater reliability, we recommend connecting both ports on every node to each switch.

We recommend the following configuration for your node.

- Your Qumulo MTU configured to match your client environment
- Two physical connections for each node, one connection for each redundant switch
- One Link Aggregation Control Protocol (LACP) port-channel for each network on each node, with the following configuration
 - Active mode
 - Slow transmit rate
 - Access port or trunk port with a native VLAN
- DNS servers
- A Network Time Protocol (NTP) server
- Firewall protocols or ports allowed for proactive monitoring
- Where N is the number of nodes, $N-1$ floating IP addresses for each node, for each client-facing VLAN

Connecting to Redundant Switches

For redundancy, we recommend connecting your cluster to dual switches. If either switch becomes inoperative, the cluster is still be accessible from the remaining switch.

- Connect the two NIC ports on your nodes to separate switches.
- The uplinks to the client network must equal the bandwidth from the cluster to the switch.
- The two ports form an LACP port channel by using a multi-chassis link aggregation group.
- Use an appropriate inter-switch link or virtual port channel.

Connecting to a Single Switch

You can connect a your cluster to a single switch. If this switch becomes inoperative, the entire cluster becomes inaccessible.

- Connect the two NIC ports on your nodes to a single switch.
- The uplinks to the client network must equal the bandwidth from the cluster to the switch.
- The two ports form an LACP port channel.

Four-Node Cluster Architecture Diagram

The following is the recommended configuration for a four-node cluster connected to an out-of-band management switch and redundant switches.

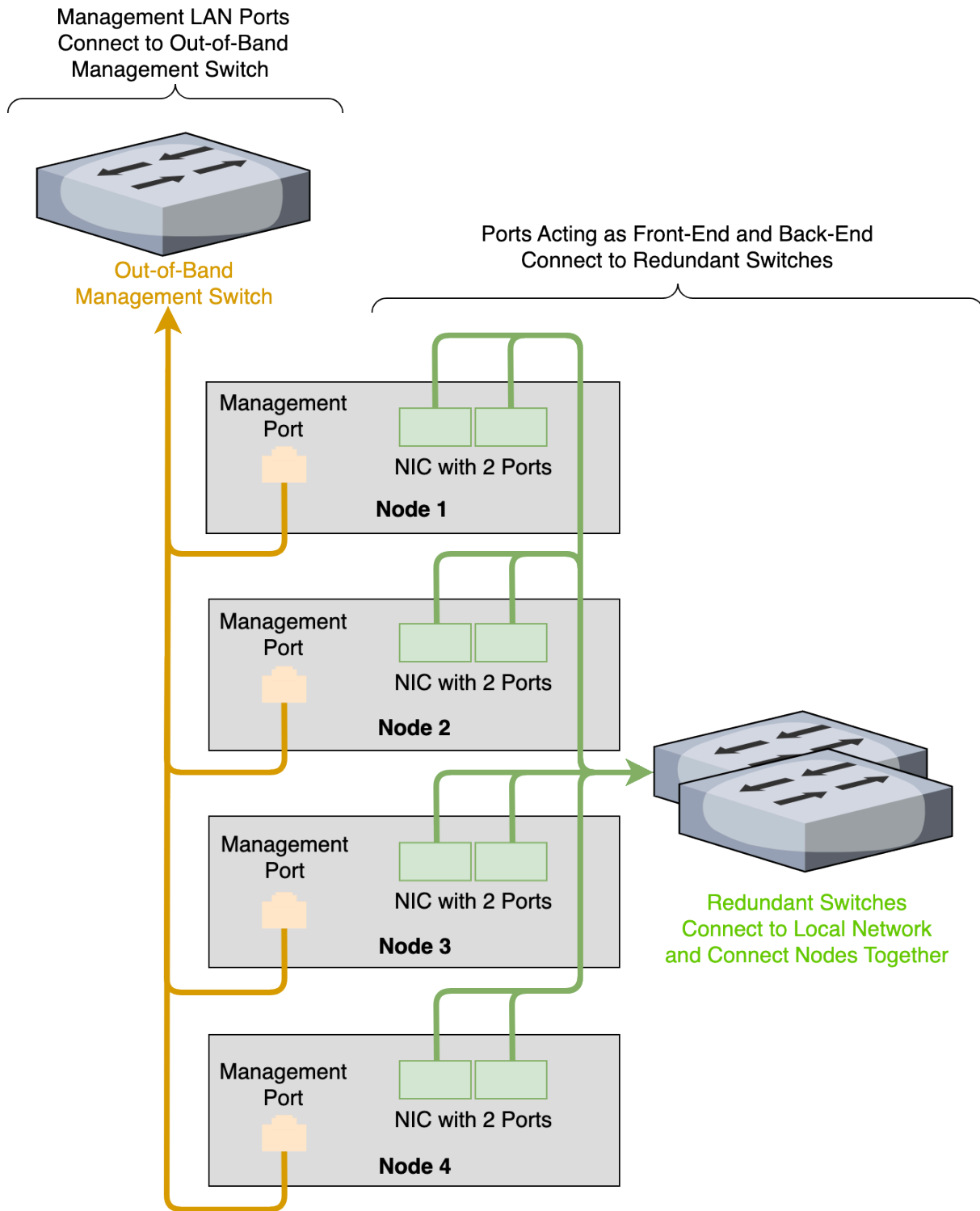

Replacing Hardware Components in Your Fsas Technologies PRIMERGY RX2540 M7 Nodes

This section explains how to replace hardware components in Fsas Technologies PRIMERGY RX2540 M7 nodes.

ⓘ Caution

- We strongly recommend engaging an on-site engineer to replace failed hardware components including but not limited to any procedure that:
 - This guide doesn't cover
 - You haven't received training on
 - Requires precautions to avoid damage caused by electrostatic discharge (ESD) by using industry standard anti-static equipment (such as gloves or wrist straps)
- We don't recommend updating firmware on Qumulo-certified hardware nodes unless the equipment manufacturer or a member of the Qumulo Care Team advises you to do so. For questions about this process, [contact the Qumulo Care Team](#).

Removing and Replacing the Top Cover

Follow the instructions in the Fsas Technologies Upgrade and Maintenance Manual: [Removing the top covers \(p. 58\)](#) .

Replacing an NIC

Your Fsas Technologies RX2540 M7 chassis contains two horizontal PCIe riser modules and a NIC inserted horizontally into the bottom module.

Follow the instructions in the Fsas Technologies Upgrade and Maintenance Manual: [Removing an expansion card from a riser module \(p. 317\)](#) .

Replacing a RAID Module Riser

Your Fsas Technologies RX2540 M7 chassis contains two RAID riser modules (for the two mirrored boot drives) inserted horizontally into the motherboard. Each riser module holds an [interposer \(controller\) board \(page 44\)](#).

Follow the instructions in the Fsas Technologies Upgrade and Maintenance Manual: [Handling riser modules \(p. 72\)](#) .



Replacing an Interposer (Controller) Board

Each of the two [RAID module risers \(page 43\)](#) on your chassis contains an interposer (controller) board which, in turn, holds an M.2 boot drive.

Follow the instructions in the Fsas Technologies Upgrade and Maintenance Manual: [Removing the M.2 interposer board \(p. 222\)](#) .

To Replace an M.2 Boot Drive

Your Fsas Technologies RX2540 M7 chassis contains two mirrored NVMe boot drives, each of which is inserted into an [interposer \(controller\) board \(page 44\)](#).

1. To replace this component, you must first power off the node.
2. [Remove the RAID module riser from the motherboard. \(page 43\)](#)
3. Follow the instructions in the Fsas Technologies Upgrade and Maintenance Manual:
 - a. [Remove the M.2 SSD \(p. 216\)](#) .
 - b. [Install an M.2 SSD \(p. 212\)](#) .

Initializing the Replacement Boot Drive

After you replace the boot drive, you must initialize the replacement boot drive by using the Qumulo Core Installer and then rebuild the replacement boot drive by using a script on the node in your cluster.

Step 1: Initialize the Replacement Boot Drive

Tip

To get the correct version of the Qumulo Core Installer for the node in your cluster, [contact the Qumulo Care Team](#)

1. [Create a Qumulo Core USB Drive Installer \(page 10\)](#).
2. Power on your node, enter the boot menu, and select your USB drive.

The Qumulo Core Installer begins to run automatically.

3. When prompted, take the following steps:
 - a. Select **[x] Perform maintenance**.
 - b. Select **[1] Boot drive reset** and then follow the prompts.

The Qumulo Core Installer initializes the boot drive.

4. When the process is complete, the node is powered down automatically.

Step 2: Rebuild the Replacement Boot Drive

1. Power on your node and log in to the node by using the `qq` CLI.
2. To get `root` privileges, run the `sudo qsh` command.
3. To stop the Qumulo Networking Services, run the `service qumulo-networking stop` command.
4. To configure the IP address for the node, run the `ip addr add` command and specify the node's IP address. For example:

```
ip addr add 203.0.113.0/CDR dev bond0
```

5. Ensure that the node can ping other nodes in the cluster.
6. Run the `rebuild_boot_drive.py` script and specify the IP address of *another node* in the cluster, the ID of the node whose boot drive has been replaced, and the password of the administrative account of the cluster. For example:

Note

If your password includes special characters such as the parenthesis (`()`) or the asterisk (`*`), use the backslash (`\`) to escape these characters.

```
/opt/qumulo/rebuild_boot_drive.py \  
  --address 203.0.113.1 \  
  --node-id 2 \  
  --username admin \  
  --password my\ (Special\ *Password
```

Follow the prompts.

7. When the process is complete, reboot the node.

Replacing an HDD

Your Fsas Technologies RX2540 M7 chassis contains 12 or 8 HDDs. For more information, see [HDD Drives \(page 37\)](#).

Note

You can replace this component without powering off the node.

Follow the instructions in the Fsas Technologies Upgrade and Maintenance Manual: [Installing 3.5-inch HDD modules \(p. 150\)](#) .

Replacing an NVMe Drive

Your Fsas Technologies RX2540 M7 chassis contains 4 NVMe drives in cages 1 (left) and 2 (middle) at the back of the node. For more information, see [NVMe Drives \(page 38\)](#).

Follow the instructions in the Fsas Technologies Upgrade and Maintenance Manual: [Rear HDD/SSD extension box \(p. 227\)](#) .

Replacing a Power Supply Unit (PSU)

Your Fsas Technologies RX2540 M7 chassis contains two PSUs.

Note

You can replace this component without powering off the node.

Follow the instructions in the Fsas Technologies Upgrade and Maintenance Manual: [Installing a hot-plug PSU \(p. 126\)](#) .

Replacing a Fan Module

Your Fsas Technologies RX2540 M7 chassis has 6 fan modules.

Follow the instructions in the Fsas Technologies Upgrade and Maintenance Manual: [Handling the fan cage \(p. 76\)](#) .

To Replace a DIMM

Your Fsas Technologies RX2540 M7 chassis has 12 DIMM slots, with a locking latch on each side of each DIMM.

1. To replace this component, you must first power off the node.
2. Follow the instructions in the Fsas Technologies Upgrade and Maintenance Manual: [Installing the memory modules \(p. 345\)](#) .

HPE Alletra 4110

Wiring Nodes and Networking Your HPE Alletra 4110 Cluster

This section explains how to wire NIC ports on HPE Alletra 4110 nodes and how to network a cluster.

Tip

To identify the eth port, run the following command:

```
for i in /sys/class/net/eth*; \
do echo $i; \
cat $i/device/uevent | \
grep -i pci_slot; \
done
```

Node NICs and Ports

Important

Your HPE Alletra 4110 node uses a split networking configuration. Ensure that the [front-end and back-end networks \(page 49\)](#) are connected and operational before creating your cluster. If only one of the networks is connected and operational during the cluster creation process, Qumulo Core deploys with the unified networking configuration.

The following diagrams show the NICs and ports on HPE Alletra 4110 node types.

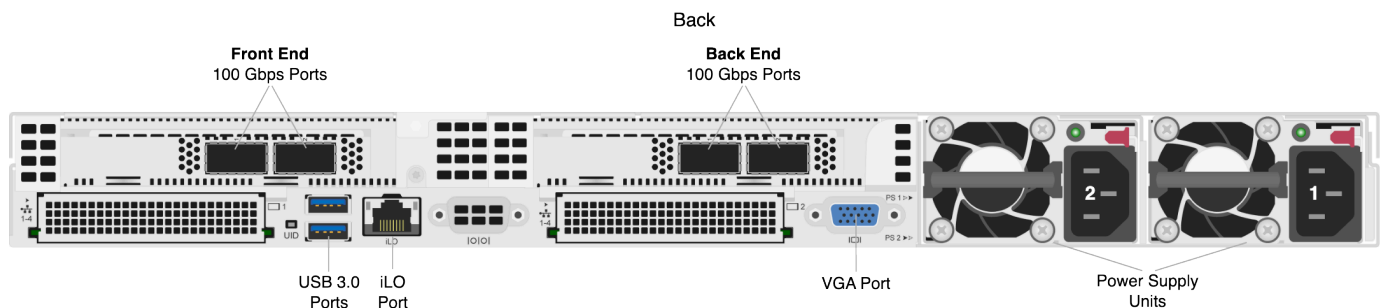

Prerequisites

- A network switch with the following criteria:

- 100 Gbps Ethernet connection
- Fully non-blocking architecture
- IPv6 compatibility
- Compatible network cables
- A sufficient number of ports for connecting all nodes to the same switch fabric
- One static IP for each node, for each defined VLAN

⚠ Important

Before you connect any Qumulo-supported equipment to your network, we strongly recommend consulting with your network engineering team.

Recommended Configuration

- One set of redundant switches for the front-end network, with an MTU that matches that of the clients that use the storage cluster. Typically, we recommend 1,500 MTU but in some instances 9,000 MTU is the optimal setting.
- One set of redundant switches for the back-end network (9,000 MTU minimum)
- One physical connection to each redundant switch, for each node
- One Link Aggregation Control Protocol (LACP) port-channel for each network (front-end and back-end) on each node with the following configuration:
 - Active mode
 - Slow transmit rate
 - Trunk port with a native VLAN
- DNS servers
- Network Time Protocol (NTP) server
- Firewall protocol or ports configured for [Qumulo Care Proactive Monitoring](#)
- Where **N** is the number of nodes, up to 10 **N-1** floating IP addresses for each node, for each client-facing VLAN
- Nodes connected at their maximum Ethernet speed (this ensures advertised performance). To avoid network bottlenecks, Qumulo validates system performance with this configuration by using clients connected at the same link speed and to the same switch as the nodes.

Connecting to Redundant Switches

This section explains how to connect a four-node cluster to dual switches for redundancy. We recommend this configuration. If either switch becomes inoperative, the cluster remains accessible through the remaining switch.

- Front End
 - Connect the two front-end 100 Gbps ports on your nodes to separate switches.
 - The uplinks to the client network must equal the bandwidth from the cluster to the switch.
 - The two ports form an LACP port channel by using a multi-chassis link aggregation group.
- Back End
 - Connect the two back-end 100 Gbps NIC ports on your nodes to separate switches.
 - Use an appropriate inter-switch link or virtual port channel.
- MTU
 - For all connection speeds, the default behavior is that of an LACP with 1,500 MTU for the front-end and 9,000 MTU for the back-end.

Connecting to a Single Switch

This section explains how to connect a four-node cluster to a single switch.

- Front End
 - Each node has two front-end 100 Gbps NIC ports connected to a single switch.
 - The uplinks to the client network must equal the bandwidth from the cluster to the switch.
 - The two ports form an LACP port channel.
- Back End
 - Each node has two back-end 100 Gbps ports connected to a single switch.
- MTU
 - For all connection speeds, the default behavior is that of an LACP with 1,500 MTU for the front-end and 9,000 MTU for the back-end.

Four-Node Cluster Architecture Diagrams

The following is the recommended configuration for a four-node cluster connected to an out-of-band management switch, redundant front-end switches, and redundant back-end switches.

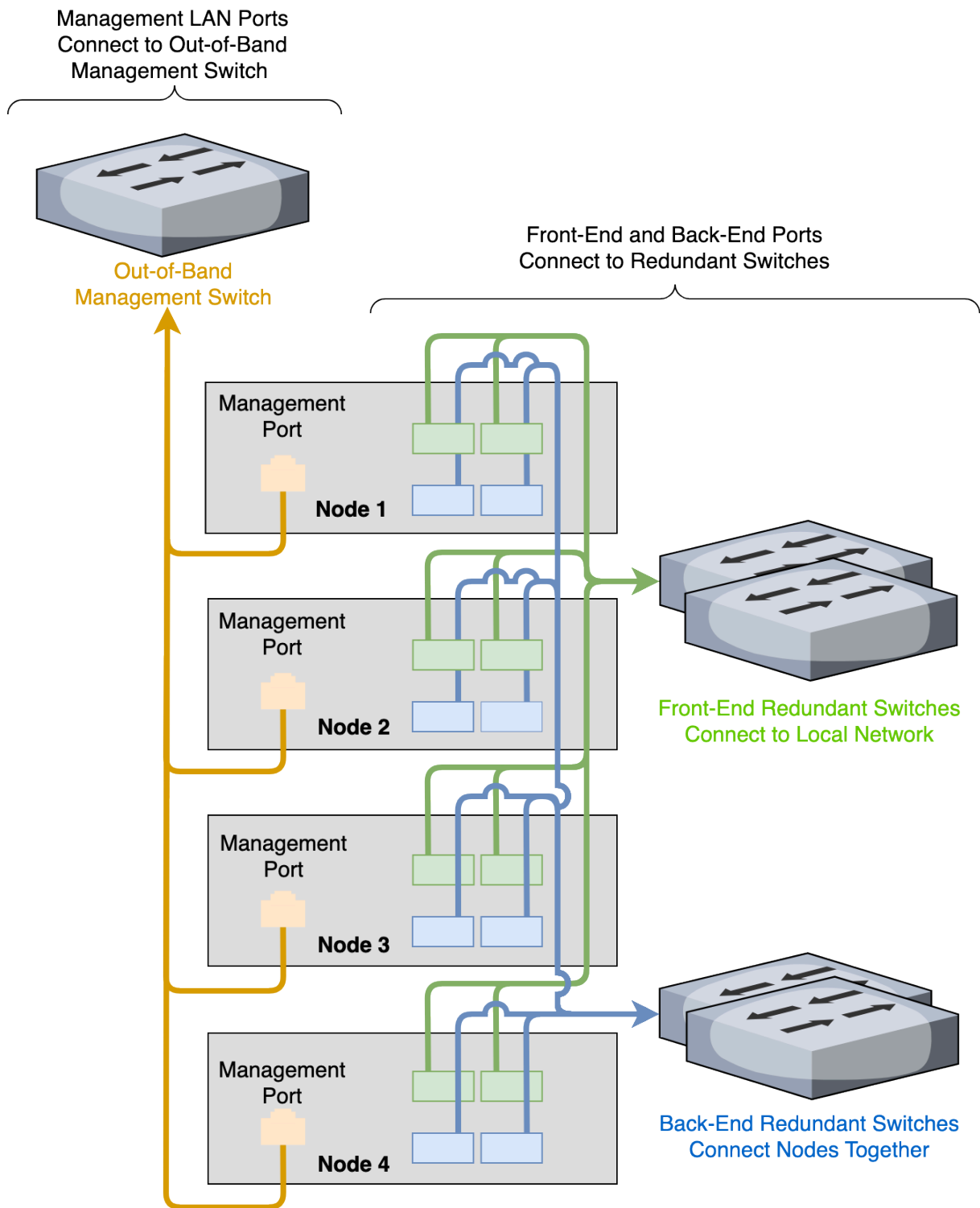

⚠ Important

For your node to work correctly, you must connect at least one port in the NIC.

Creating and Configuring a Qumulo Cluster with HPE Alletra 4110 Nodes

This section explains how to prepare HPE Alletra 4110 nodes for creating a Qumulo cluster. This guide is for system administrators, professional service providers, and colleagues in your organization who are responsible for installing and configuring server hardware.

✓ Tip

For information about installing your node and replacing hardware components, see [HPE Alletra 4110 System Maintenance and Service Guide](#) and [HPE Alletra 4110 System Setup and Installation Guide](#) in the HPE documentation.

Prerequisites

[Qumulo Core USB Drive Installer](#)

Step 1: Verify Your Node

1. Shut down your node and connect a display, a keyboard, and a mouse to it.
2. Plug the [Qumulo Core USB Drive Installer](#) into an available USB port on the node and then press the power button.

Step 2: Boot by Using the Qumulo Core USB Drive Installer

1. On the HPE Alletra boot screen, press F11.

📘 Note

The [Boot Menu](#) page might take a few minutes to appear.

2. On the [Boot Menu](#) page, to perform a one-time boot, do one of the following:
 - If the [Legacy BIOS One-Time Boot Menu](#) option is available, click it.
 - If the [Legacy BIOS One-Time Boot Menu](#) option is unavailable, click [Generic USB Boot](#) and continue to run the Field Verification Tool (FVT).
3. In the [Question](#) dialog box, click [OK](#).

📘 Note

The [Default Boot Override Options](#) page might take a few minutes to appear.

4. In the [Default Boot Override Options](#) menu, select 2) [One Time Boot to USB DriveKey](#).

Step 3: Run the Field Verification Tool (FVT)

After the node reboots, the Qumulo Installer runs automatically.

1. Choose **[1] Factory reset (DESTROYS ALL DATA)**.
2. To perform a clean installation of Qumulo Core on your node, type **DESTROY ALL DATA** (case-sensitive).
3. Review the verification results and consider the following before proceeding with the installation.
 - If the **FVT Passed!** message appears, select **[1] Install Qumulo Core**.
 - If **FAIL** messages appear, use one of the following resolutions.
4. When the FVT passes all checks, select **[1] Install Qumulo Core**.

Fixable Issues During Installation

If the FVT finds fixable issues, it prompts you to auto-correct any detected issues, depending on your installation scenario. Issues that the FVT can auto-correct include the following:

- BIOS Configuration
 - Drive firmware
 - NVMe sector size
 - NIC mode
 - NIC firmware
 - Boot order
1. To attempt auto-correction, select **[1] Run FVT Flash**. This will try to fix issues then reboot.
If the fixes are successful, the FVT reboots the node automatically.
 2. To re-attempt verification, [boot by using the Qumulo Core USB Drive Installer \(page 51\)](#) and then continue the installation.

Non-Fixable Issues

If the FVT is unable to auto-correct any issues, the message **Not fixable issues were detected** appears, providing reasons for failure.

For help with troubleshooting your node, [contact the Qumulo Care Team](#).

Step 4: Create and Configure Your Cluster

⚠ Important

Your HPE Alletra 4110 node uses a split networking configuration. Ensure that the [front-end and back-end networks \(page 49\)](#) are connected and operational before creating your cluster. If only one of the networks is connected and operational during the cluster creation process, Qumulo Core deploys with the unified networking configuration.

1. Review the **End User Agreement**, click **I agree to the End User Agreement**, and then click **Submit**.
2. Name your cluster.
3. On the **1. Set up cluster** page, select the nodes to add to your cluster.

As you select nodes, the installer updates the total capacity of your cluster at the bottom of the page.

📘 Note

If any nodes are missing, confirm that they are powered on and connected to the same network.

4. Confirm that the individual nodes have the expected capacity.
5. On the **2. Confirm cluster protection level** page, Qumulo Core selects the recommended 2, 3, or 4-drive protection level based on your cluster size and node type.
6. If the **Customize Protection Level** option appears, you can increase your system resilience by selecting 3- or 4-drive protection.

⚠ Important

- Qumulo Core 6.1.0.1 and 6.1.1 support Adaptive Data Protection by letting you reconfigure your cluster's fault tolerance level and storage efficiency only when you add nodes to your cluster.

Depending on your cluster, Qumulo Core shows configuration options that offer better fault tolerance levels, better storage efficiency, or both benefits. To enable Adaptive Data Protection for your cluster, you must [contact the Qumulo Care Team](#).

- In Qumulo Core 6.1.2 (and higher), you can change your cluster's data protection configuration when you add or replace nodes by using the `qq` CLI.
- Using 3- or 4-drive protection reduces the total capacity of your cluster.

7. Enter a password for the administrative account and click **Create Cluster**.
8. To access the Qumulo Core Web UI, connect to any node by entering its IP address into a browser.

Front and Internal Drive Bays on HPE Alletra 4110 Nodes

This section shows the locations of front drive bays in HPE Alletra 4110 nodes.

There are 20 drive bay at the front of the HPE Alletra 4110 node, populated according to your node type.

307TB and 153TB Nodes

In 307TB and 153TB nodes, all drive bays are populated.



38TB Nodes

In 38TB Nodes, some drive bays are empty.

i Note

In the following diagram, empty drive bays appear in gray.

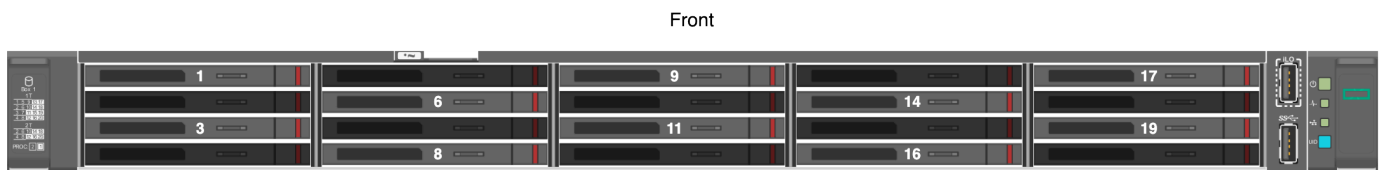

NVMe Boot Drive

The NVMe boot drive is located inside the HPE NS204i-u Hot Plug Boot Optimized Storage Device.

! Important

- For help with locating the NS204i-u device and with replacement procedures, [contact HPE support](#).
- Before you remove the boot drive, [contact the Qumulo Care Team](#) for additional instructions.

For more information, see the following HPE documentation:

- Installing the Drives onto HPE NS204i-u Boot Device
- Removing and Replacing the M.2 Boot Device

i Note

The instructions for installing the HPE NS204i-u Boot Device and M.2 Boot Device are similar.

Panel LEDs on HPE Alletra 4110 Nodes

This section explains the LEDs on HPE Alletra 4110 nodes, including front panel LEDs and buttons and rear panel LEDs.

Front Panel LEDs and Buttons

On the front, right side of your node, there are four LEDs. The following diagram shows the LEDs and buttons on the front panel.

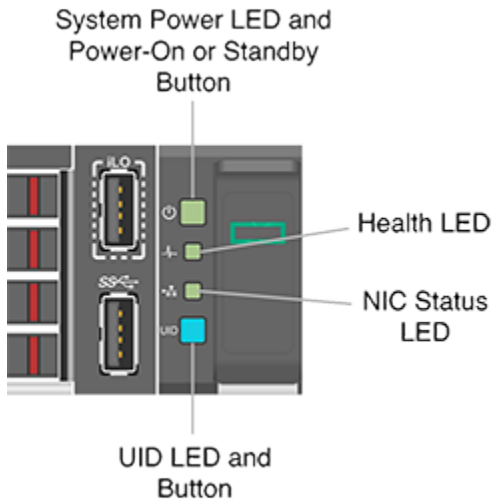

Label	Color and Behavior	Description
System Power LED and Power On or Standby Button	● (solid green)	System is powered on
System Power LED and Power On or Standby Button	● (1 s. blinking green)	Performing power-on sequence
System Power LED and Power On or Standby Button	● (solid amber)	System is on standby
System Power LED and Power On or Standby Button	Off	System is powered off
Health LED	● (solid green)	Health is normal
Health LED	● (1 s. blinking green)	iLO is rebooting
Health LED	● (blinking amber)	System state degraded

Label	Color and Behavior	Description
Health LED	● (1 s. blinking red)	System state critical
NIC Status LED	● (solid green)	Linked to network
NIC Status LED	● (1 s. flashing green)	Network active
NIC Status LED	Off	No network activity
UID Button and LED	● (solid blue)	UID activated
UID Button and LED	● (1 s. blinking blue)	Remote management or firmware upgrade in progress
UID Button and LED	● (0.25 s. blinking blue)	Manual iLO reboot sequence initiated
UID Button and LED	● (0.125 s. blinking blue)	Manual iLO reboot sequence in progress
UID Button and LED	● (1 fast blue blink) then 3 s. stop	iLO service port status is Complete
UID Button and LED	● (4 medium blue blinks) then 1 s. stop	iLO service port status is Busy
UID Button and LED	● (8 fast blue blinks) then 1 s. stop	iLO service port status is Error
UID Button and LED	● Off	UID deactivated

Rear Panel LED

On the back of your node, there is a UID LED.

Color and Behavior	Description
● (solid blue)	UID activated
● (1 s. blinking blue)	Remote management or firmware upgrade in progress
● (0.25 s. blinking blue)	Manual iLO reboot sequence has been initiated
● (0.125 s. blinking blue)	Manual iLO reboot sequence is in progress

Color and Behavior	Description
Off	UID deactivated

Configuring Integrated Lights Out (iLO) on HPE Alletra 4110 Nodes

This section explains how to configure Integrated Lights Out (iLO) on HPE Alletra 4110 nodes.

Prerequisites

To configure the iLO port, you must have root access to the client-facing network through SSH. For example, you can run the `sudo -s` command.

⚠ Important

Access to the iLO port on a public LAN can have serious security implications because it can grant anyone with credentials direct access to your server's hardware and console. Follow security best practices when implementing iLO access.

How the iLO Port Works

Your node provides iLO support for out-of-band maintenance access even when the node is plugged in but powered off. The following diagram shows the location of the iLO port.

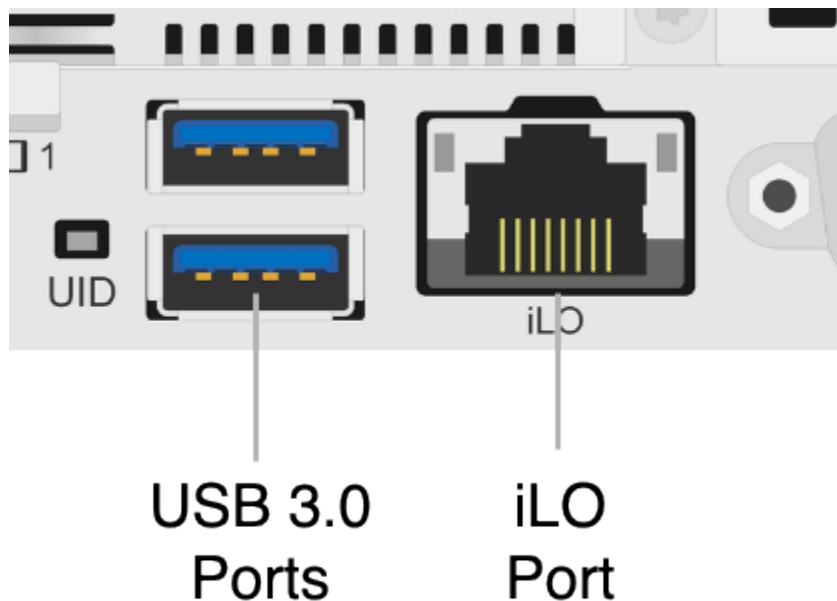

Your nodes receive DHCP address assignments by default. When you configure a node's iLO port, you can access the node by using the IP address (that the DHCP server assigns to the node) and a browser that supports HTML5, Java, or .NET.

⚠ Important

We strongly recommend separating your iLO access network from your client-facing network.

To access iLO configuration from the BIOS System Utilities menu, press F9.

📘 Note

The IMPI username and password are unrelated to your Qumulo administrative credentials.

iLO Configuration

To configure the iLO port, you must use `ipmitool`. For more information, see the following HPE resources:

- [HPE iLO 6 User Guide](#)
- [HPE iLO IPMI User Guide](#)

Replacing Hardware Components in Your HPE Alletra 4110 Nodes

This section explains how to replace hardware components in HPE Alletra 4110 nodes.

⚠ Caution

- We strongly recommend engaging an on-site engineer to replace failed hardware components including but not limited to any procedure that:
 - This guide doesn't cover
 - You haven't received training on
 - Requires precautions to avoid damage caused by electrostatic discharge (ESD) by using industry standard anti-static equipment (such as gloves or wrist straps)
- We don't recommend updating firmware on Qumulo-certified hardware nodes unless the equipment manufacturer or a member of the Qumulo Care Team advises you to do so. For questions about this process, [contact the Qumulo Care Team](#).

To Perform the Part Replacement Procedure by Using the FVT

When you replace a component such as the motherboard or a NIC card in your node, you must ensure that the firmware version and configuration are correct for your new components. To do this, you must perform the part replacement procedure by using the FVT.

1. Boot by using the latest version of the Qumulo Core USB Drive Installer.
2. Select **[*] Perform maintenance**.
3. Select **[2] Perform automatic repair after part replacement (non-destructive)**.

The part replacement procedure runs and the **FVT passed!** message appears.

📘 Note

In some cases, after the part replacement procedure, the message **FIX: Run the FVT flash command.** appears. Enter 1 as you would for a fixable issue to reboot the node and then repeat the part replacement procedure.

Replacing an NVMe Drive

Your HPE Alletra 4110 chassis contains either 20 or 10 NVMe drives.

For information about replacing an NVMe drive, see [Storage Drives \(NVMe\)](#) in the HPE documentation.

Replacing an M.2 Boot Drive

Your HPE Alletra 4110 chassis contains one NVMe boot drive in a server module.

For information about replacing an M.2 boot drive, see [Installing an M.2 Solid State Drive](#) in the HPE documentation.

Initializing the Replacement Boot Drive

After you replace the boot drive, you must initialize the replacement boot drive by using the Qumulo Core Installer and then rebuild the replacement boot drive by using a script on the node in your cluster.

Step 1: Initialize the Replacement Boot Drive

✓ Tip

To get the correct version of the Qumulo Core Installer for the node in your cluster, [contact the Qumulo Care Team](#)

1. [Create a Qumulo Core USB Drive Installer \(page 10\)](#).
2. Power on your node, enter the boot menu, and select your USB drive.

The Qumulo Core Installer begins to run automatically.

3. When prompted, take the following steps:
 - a. Select `[x] Perform maintenance`.
 - b. Select `[1] Boot drive reset` and then follow the prompts.

The Qumulo Core Installer initializes the boot drive.

4. When the process is complete, the node is powered down automatically.

Step 2: Rebuild the Replacement Boot Drive

1. Power on your node and log in to the node by using the `qq` CLI.
2. To get `root` privileges, run the `sudo qsh` command.
3. To stop the Qumulo Networking Services, run the `service qumulo-networking stop` command.
4. To configure the IP address for the node, run the `ip addr add` command and specify the node's IP address. For example:

```
ip addr add 203.0.113.0/CDR dev bond0
```

5. Ensure that the node can ping other nodes in the cluster.
6. Run the `rebuild_boot_drive.py` script and specify the IP address of *another node* in the cluster, the ID of the node whose boot drive has been replaced, and the password of the administrative account of the cluster. For example:

Note

If your password includes special characters such as the parenthesis (()) or the asterisk (*), use the backslash (\) to escape these characters.

```
/opt/qumulo/rebuild_boot_drive.py \  
  --address 203.0.113.1 \  
  --node-id 2 \  
  --username admin \  
  --password my\ (Special\ *Password
```

Follow the prompts.

7. When the process is complete, reboot the node.

Replacing a Power Supply Unit (PSU)

Your HPE Alletra 4110 chassis contains two PSUs.

For information about replacing a PSU, see [Power Supply](#) in the HPE documentation.

Replacing a Fan

Your HPE Alletra 4110 chassis has seven fans at the back of the chassis.

For information about replacing a fan, see [System Fans](#) in the HPE documentation.

Replacing a DIMM

Your HPE Alletra 4110 chassis has 24 DIMM slots.

For information about replacing a DIMM, see [DIMM Installation](#) in the HPE documentation.

Note

To identify which DIMM failed, you must use the baseboard management controller (BMC) on the node or another hardware monitoring solution.

HPE Apollo 4200 Gen9

Wiring Nodes and Networking Your HPE Apollo 4200 Gen9 Cluster

This section explains how to wire NIC ports on HPE Apollo 4200 Gen9 nodes and how to network a cluster.

⚠ Important

The HPE Apollo 4200 Gen9 90T, 180T, and 288T platforms will reach their End of Platform Support (EoPS) on April 20, 2025.

This platform uses a *unified networking configuration* in which the same NIC handles back-end and front-end traffic. In this configuration, each networking port provides communication with clients and between nodes. You can connect the NIC's ports to the same switch or to different switches.

✓ Tip

To identify the eth port, run the following command:

```
for i in /sys/class/net/eth*; \  
do echo $i; \  
cat $i/device/uevent | \  
grep -i pci_slot; \  
done
```

Node NICs and Ports

The following diagrams show the NICs and ports on HPE Apollo 4200 Gen9 node types.

288T

📘 Note

Currently, NIC2 on this model is unused.

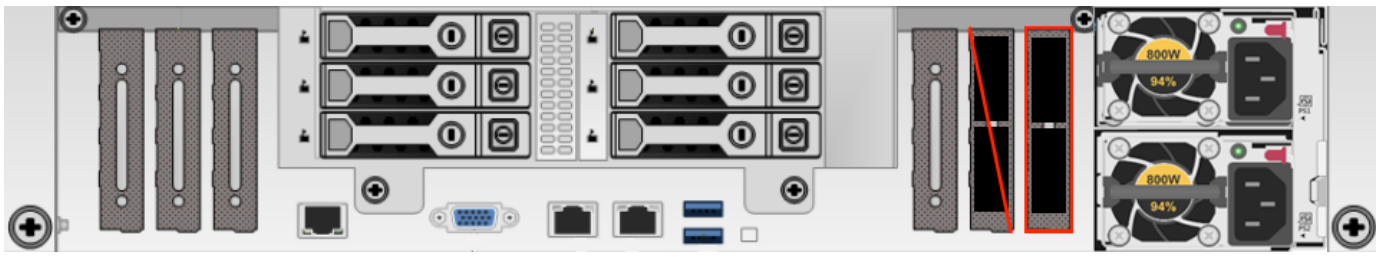

288T

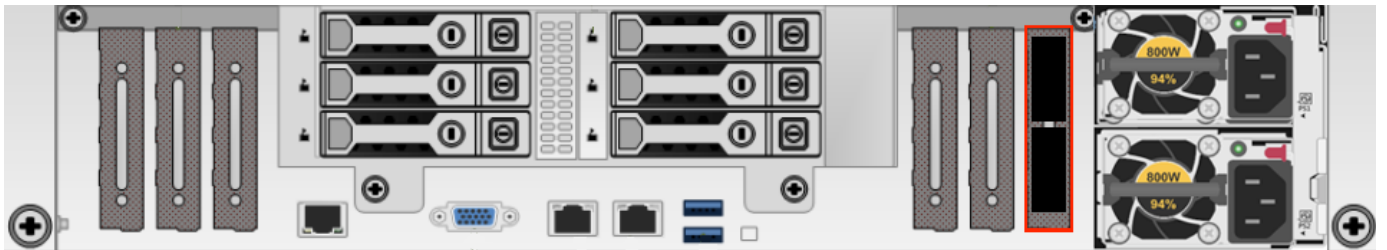

180T

Note

Currently, NIC2 on this model is unused.

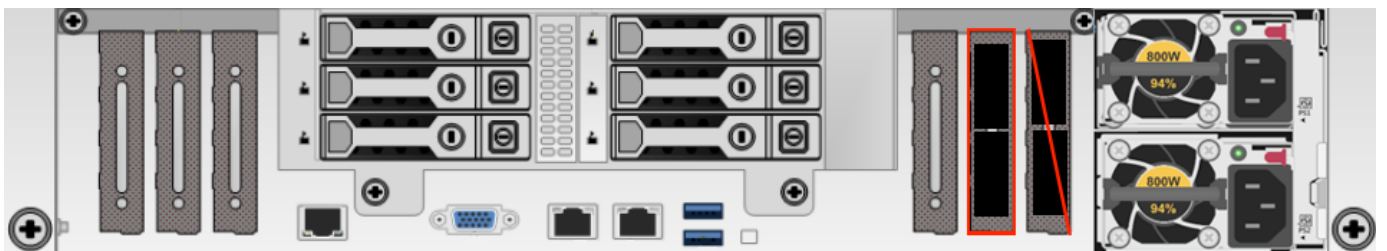

90T

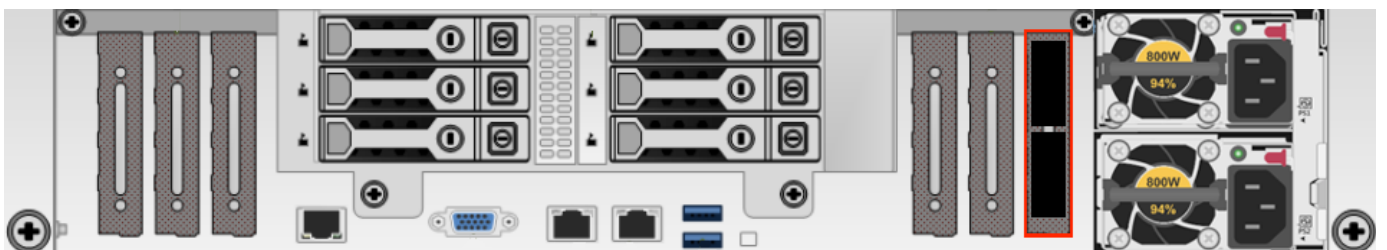

Prerequisites

- A network switch with the following criteria:
 - 40 Gbps Ethernet connection

- Fully non-blocking architecture
- IPv6 compatibility
- Compatible network cables
- A sufficient number of ports for connecting all nodes to the same switch fabric
- One static IP for each node, for each defined VLAN

⚠ Important

Before you connect any Qumulo-supported equipment to your network, we strongly recommend consulting with your network engineering team.

Recommended Configuration

- Two redundant switches
- One physical connection to each redundant switch, for each node
- One Link Aggregation Control Protocol (LACP) port-channel for each node with the following configuration:
 - Active mode
 - Slow transmit rate
 - Trunk port with a native VLAN
 - Enabled IEEE 802.3x flow control (full-duplex mode)
- DNS servers
- Network Time Protocol (NTP) server
- Firewall protocol or ports configured for [Qumulo Care Proactive Monitoring](#)
- Where **N** is the number of nodes, up to 10 **N-1** floating IP addresses for each node, for each client-facing VLAN

i Note

The number of floating IP addresses depends on your workflow and on the clients that connect to the cluster, with a minimum of two floating IP addresses for each node, for each client-facing VLAN, but with no more than ten floating IP addresses for each node, for each client-facing VLAN.

- Nodes connected at their maximum Ethernet speed (this ensures advertised performance). To avoid network bottlenecks, Qumulo validates system performance with this configuration by using clients connected at the same link speed and to the same

switch as the nodes.

Connecting to Redundant Switches

This section explains how to connect a four-node HPE cluster to dual switches for redundancy. We recommend this configuration for HPE hardware. If either switch becomes inoperative, the cluster remains accessible through the remaining switch.

- Connect the two 40 Gbps ports on the nodes to separate switches.
- Use at least one port on both switches as an uplink to the client network. To ensure an acceptable level of physical network redundancy and to meet the necessary client access throughput rates, use an appropriate combination of 10 Gbps, 25 Gbps, 40 Gbps, or 100 Gbps network uplinks.
- Use at least one peer link between the switches.

Connecting to a Single Switch

This section explains how to connect a four-node HPE cluster to a single switch.

i Note

If the switch becomes inoperative, the cluster becomes inaccessible.

- Connect two 40 Gbps ports to the switch.
- Connect any uplink ports to the client network.

Creating and Configuring a Qumulo Cluster with HPE Apollo 4200 Gen9 Nodes

This section explains how to prepare HPE Apollo 4200 Gen9 nodes for creating a Qumulo cluster. This guide is for system administrators, professional service providers, and colleagues in your organization who are responsible for installing and configuring server hardware.

⚠ Important

The HPE Apollo 4200 Gen9 90T, 180T, and 288T platforms will reach their End of Platform Support (EoPS) on April 20, 2025.

Prerequisites

[Qumulo Core USB Drive Installer](#)

Step 1: Verify Your Node

1. Shut down your node and connect a display, a keyboard, and a mouse to it.
2. Plug the [Qumulo Core USB Drive Installer](#) into an available USB port on the node and then press the power button.
3. On the HPE ProLiant boot screen, do one of the following:
 - If the **Boot Mode: Legacy BIOS** message appears, skip the rest of this section and continue to [boot by using the Qumulo Core USB Drive Installer \(page 69\)](#).
 - If the **Boot Mode: Legacy BIOS** message doesn't appear, press F9.
4. On the System Utilities page, click **System Configuration > BIOS/Platform Configuration (RBSU) > Boot Options**.
5. On the **Boot Options** page, set **Boot Mode** to **Legacy BIOS Mode** and then press F10.
6. Press Esc until you return to the main page.
7. Click **Reboot the System**.

Step 2: Boot by Using the Qumulo Core USB Drive Installer

⚠ Caution

If your node contains any live data, *don't* run the FVT.

1. On the HPE ProLiant boot screen, press F11.

Note

The Boot Menu page might take a few minutes to appear.

2. On the Boot Menu page, to boot into the Legacy BIOS One-Time Boot Menu, press Enter.
3. In the Select ENTER to enter the Legacy BIOS One-Time Boot Menu or Esc to cancel. dialog box, press Enter.
4. From the Default Boot Override Options menu, select 2) One Time Boot to USB DriveKey. Wait for Qumulo Installer to load.
5. Select [1] Factory reset (DESTROYS ALL DATA) and when prompted type **DESTROY ALL DATA**.
The platform name and SmartArray mode appear.
6. Configure the encryption on your node.
 - If the SmartArray mode is Secure, RAID, or Encrypted, select 2) no, continue install in Non-Secure mode.
 - If the SmartArray mode is Not Secure, HBA, or Unencrypted:
 1. Select 1) SET ENCRYPTION, set SmartArrays in RAID mode, destroy all data, reboot node.
 2. After the node reboots, select 1) CONFIGURE ENCRYPTION, Set up encryption, input new keys.
The rules for the cryptographic login password and master key appear.

Caution

To avoid data loss, save your credentials.

Step 3: Run the Field Verification Tool (FVT)

1. Select 1) FVT, Enter FVT sub menu.
2. To update the node components to required versions, choose 1) FLASH, Flash components to required versions.
3. Do one of the following:
 - If the FVT verification passes, select 2) no, return to menu, run FVT to continue install.
 - If the FVT flashes firmware, select 1) REBOOT, reboot node in 5 seconds and the continue from step 2.

Step 4: Install Qumulo Core by Using the USB Drive Installer

Perform the following steps on every node in your cluster.

1. In the FVT, select 2) no, continue install.

When the installation is complete, the node shuts down automatically.

2. Remove the USB drive and power on the node.

Step 5: Create and Configure Your Cluster

1. Review the **End User Agreement**, click **I agree to the End User Agreement**, and then click **Submit**.
2. Name your cluster.
3. On the **1. Set up cluster** page, select the nodes to add to your cluster.

As you select nodes, the installer updates the total capacity of your cluster at the bottom of the page.

Note

If any nodes are missing, confirm that they are powered on and connected to the same network.

4. Confirm that the individual nodes have the expected capacity.
5. On the **2. Confirm cluster protection level** page, Qumulo Core selects the recommended 2, 3, or 4-drive protection level based on your cluster size and node type.
6. If the **Customize Protection Level** option appears, you can increase your system resilience by selecting 3- or 4-drive protection.

⚠ Important

- Qumulo Core 6.1.0.1 and 6.1.1 support Adaptive Data Protection by letting you reconfigure your cluster's fault tolerance level and storage efficiency only when you add nodes to your cluster.

Depending on your cluster, Qumulo Core shows configuration options that offer better fault tolerance levels, better storage efficiency, or both benefits. To enable Adaptive Data Protection for your cluster, you must [contact the Qumulo Care Team](#).

- In Qumulo Core 6.1.2 (and higher), you can change your cluster's data protection configuration when you add or replace nodes by using the `qq` CLI.
- Using 3- or 4-drive protection reduces the total capacity of your cluster.

7. Enter a password for the administrative account and click **Create Cluster**.
8. To access the Qumulo Core Web UI, connect to any node by entering its IP address into a browser.

Front and Rear Drive Bays on HPE Apollo 4200 Gen9 Nodes

This section shows the front large form factor (LFF) and rear small form factor (SFF) drive bays in HPE Apollo 4200 Gen9 nodes.

⚠ Important

The HPE Apollo 4200 Gen9 90T, 180T, and 288T platforms will reach their End of Platform Support (EoPS) on April 20, 2025.

Front LFF Drive Row



Second LFF Drive Row

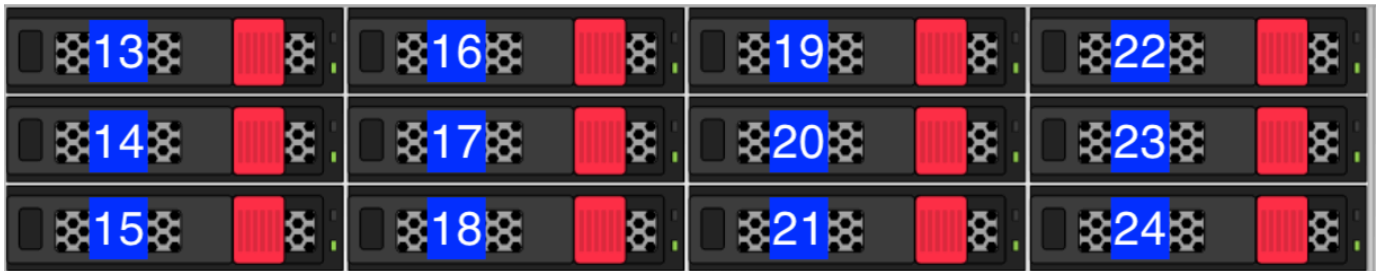

Rear SFF Hot-Plug Drives

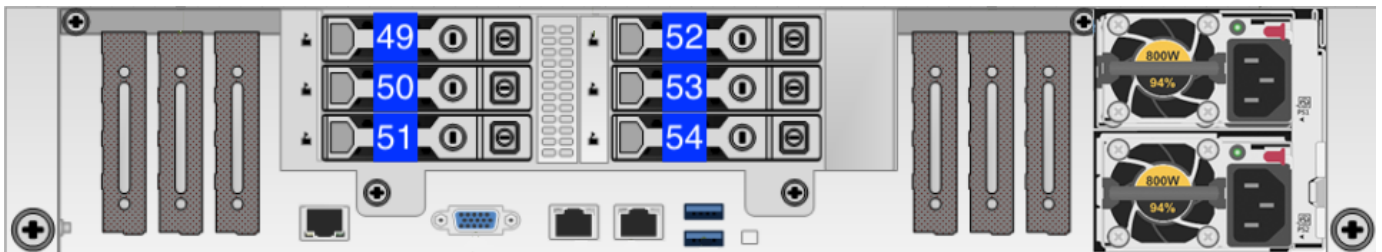

Boot Drive

⚠ Important

Before you remove the boot drive [contact the Qumulo Care Team](#) for additional instructions.

The following diagram shows the boot drive in HPE Apollo 4200 Gen9 90T, 180T, and 288T nodes.

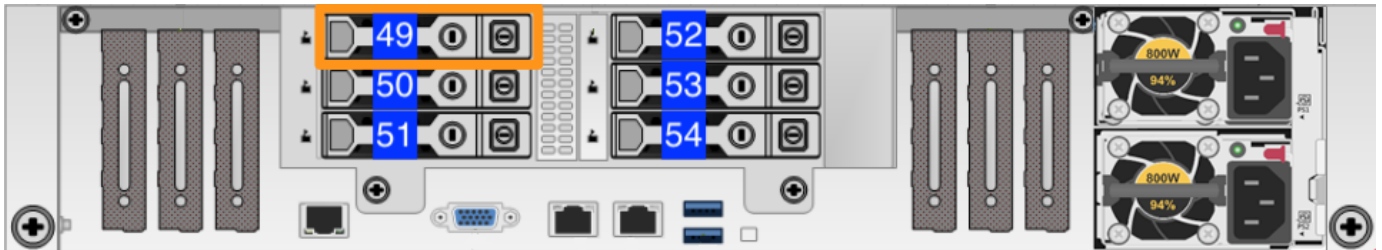

Panel LEDs on HPE Apollo 4200 Gen9 Nodes

This section explains the LEDs on HPE Apollo 4200 Gen9 nodes, including front panel LEDs and buttons, power fault LEDs, and rear panel LEDs. You can use these LEDs to diagnose hardware health issues.

⚠ Important

The HPE Apollo 4200 Gen9 90T, 180T, and 288T platforms will reach their End of Platform Support (EoPS) on April 20, 2025.

Front Panel LEDs and Buttons

To locate the front panel LEDs, use the following diagram.

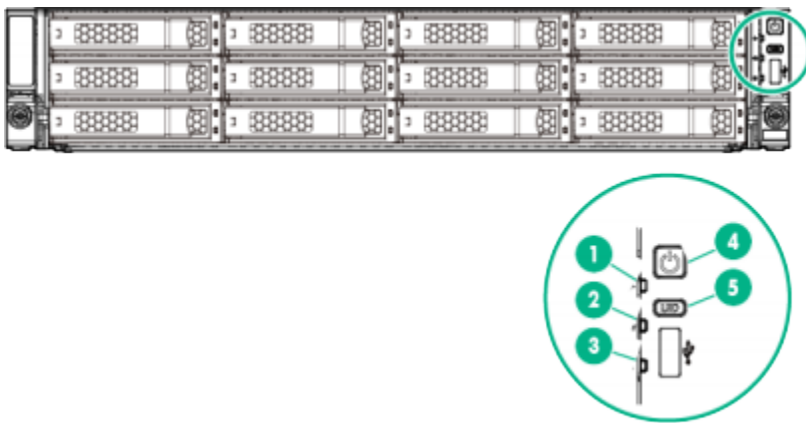

1. Health LED

- ● Solid Green: Normal
- ● Flashing Green: (1 flash each second) iLO is rebooting
- ● Flashing Amber: System degraded
- ● Flashing Red: (1 flash each second) System critical

i Note



If the Health LED indicates a degraded or critical state, review the system integrated management log (IML) or use iLO to review the system health status.

2. NIC Status LED

- ● Solid Green: Link to network
- ● Flashing Green: (1 flash each second) Network active

- Off: No network activity

3. Front Drive Health or Thermal LED



-  Solid Green: Drives which the SAS expander supports are functional. This applies to all front drives and the rear drives connected to the front drive cage 2 backplane.
-  Solid Amber: Failure or predictive failure of one or more drives that the SAS expander supports. This applies to all front drives and to the rear drives connected to the front drive cage 2 backplane.
-  Flashing Amber: (1 flash each second) The temperature sensor in one or more front drives is about to reach the thermal threshold. You must immediately slide the front drive cages back into the chassis and keep them there until the LED turns green.

Note



This LED behavior depends on the iLO 08-HD Max sensor reading.

- Off: No power present

4. Power On or Standby Button and System Power LED

-  Solid Green: System on
-  Flashing Green: (1 flash each second) Performing power-on sequence
-  Solid Amber: System in standby mode
- Off: No power present

5. UID Button and LED

-  Solid Blue: Activated
-  Flashing Blue:
 - 1 flash each second: Remote management or firmware upgrade in progress
 - 4 flashes each second: iLO manual reboot sequence initiated
 - 8 flashes each second: iLO manual reboot sequence in progress
- Off: Deactivated

Note

If the (3) Front Drive Health or Thermal LED, or the (4) Power On or Standby Button and System Power LED is off, one of the following conditions is possible:

- Facility power not present
- Power cord detached
- No power supplies installed
- Power supply failure
- Front I/O cable disconnected

Power Fault LEDs

If the (1) Health LED, (2) NIC status LED, (4) Power On and Standby button, and (4) System Power LED, and the (5) UID Button and LED (5) flash simultaneously, a power fault has occurred. The following table lists the LED behavior corresponding to affected subsystems.

Number of LED Flashes	Affected Subsystem
1	System board
2	Processor
3	Memory
4	Riser board PCIe slots
5	FlexibleLOM
6	Removable HPE Flexible Smart Array controller or Smart SAS HBA controller
7	System board PCIe slots
8	Power backplane or storage backplane
9	Power supply

Rear Panel LEDs

To locate the rear panel LEDs, use the following diagram.

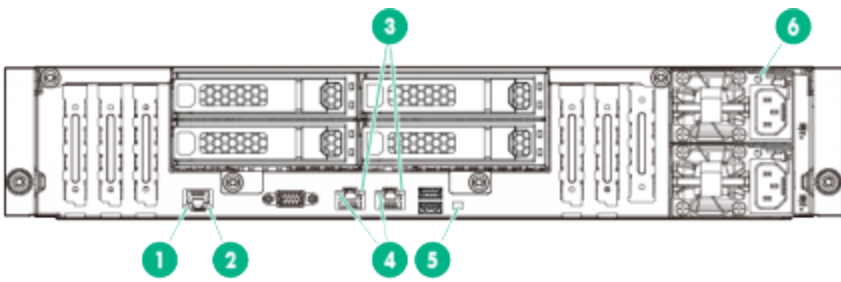

1. Dedicated iLO Activity LED

- ● Solid Green: Link to network
- ● Flashing Green: Network active
- Off: No network activity

2. Dedicated iLO Link LED

- ● Green: Network link
- Off: No network link

3. NIC Activity LED

- ● Solid Green: Link to network
- ● Flashing Green: Network active
- Off: No network activity

4. NIC Link LED

- ● Green: Network link
- Off: No network link

5. UID LED

- ● Solid Blue: Activated
- ● Flashing Blue:
 - 1 flash each second: Remote management or firmware upgrade in progress
 - 4 flashes each second: iLO manual reboot sequence initiated
 - 8 flashes each second: iLO manual reboot sequence in progress
- Off: Deactivated

6. Power Supply LED

- ● Solid Green: Normal
- Off: One or more of the following conditions exist:

- Power unavailable
- Power supply failed
- Power supply in standby mode
- Power supply error

Drive LEDs on HPE Apollo 4200 Gen9 Nodes

This section explains the LEDs of large form factor (LFF) and small form factor (SFF) drives in HPE Apollo 4200 Gen9 nodes.

⚠ Important

The HPE Apollo 4200 Gen9 90T, 180T, and 288T platforms will reach their End of Platform Support (EoPS) on April 20, 2025.

Large Form Factor (LFF) Drive LEDs

To locate the LFF drive LEDs, use the following diagram.

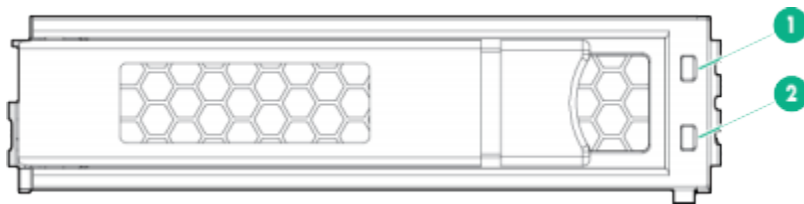

You can determine the current state of an LFF drive by reviewing the status of the following LEDs:

1. Fault or UID LED
 - ● Amber
 - ● Blue
2. Online or Activity LED
 - ● Green

The following table explains the various combinations of the two LFF LEDs.

Online or Activity LED	Fault or UID LED	Description
On, off, or flashing	Alternating amber and blue	One or more of the following conditions exist: <ul style="list-style-type: none">• The drive has failed.• This system received a predictive failure alert about the drive.• A management application has selected the drive.



Online or Activity LED	Fault or UID LED	Description
On, off, or flashing	Solid blue	One or more of the following conditions exist: <ul style="list-style-type: none"> • The drive is operating normally. • A management application has selected the drive.
On	Flashing amber	This system received a predictive failure alert about the drive. Replace the drive as soon as possible.
On	Off	The drive is online but isn't active currently.
1 flash each second	Flashing amber	Don't remove the drive. Removing the drive might terminate the current operation and cause data loss. The drive is part of an array that is undergoing capacity expansion or stripe migration. However, the system received a predictive failure alert about the drive. To minimize the risk of data loss, don't remove the drive until the expansion or migration is complete.
1 flash each second	Off	Don't remove the drive. Removing the drive might terminate the current operation and cause data loss. The drive is rebuilding, erasing, or is part of an array that is undergoing capacity expansion or stripe migration.
4 flashes each second	Flashing amber	The drive is active but it received a predictive failure alert. Replace the drive as soon as possible.
4 flashes each second	Off	The drive is active and is operating normally.
Off	Solid amber	The drive has a critical fault condition and the controller has placed it offline. Replace the drive as soon as possible.
Off	Flashing amber	This system received a predictive failure alert about the drive. Replace the drive as soon as possible.
Off	Off	The drive is offline, a spare, or isn't configured as part of an array.

Small Form Factor (SFF) Drive LEDs

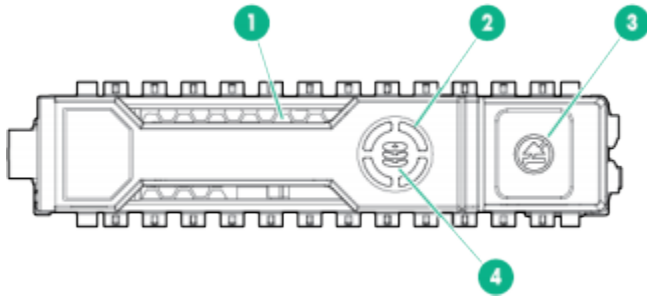
To locate the SFF drive LEDs, use the following diagram.



1. Locate LED

-  **Solid Blue:** A host application is identifying the drive.
-  **Flashing Blue:** The drive carrier firmware is updating or requires an update.

Note

The Locate LED is behind the release lever. When it is illuminated, it is visible.





2. Activity Ring LED

-  **Rotating Green:** Drive activity
- **Off:** No drive activity

3. Don't Remove LED

-  **Solid White:** Don't remove the drive. Removing the drive causes one or more of the logical drives to fail.
- **Off:** Removing the drive doesn't cause a logical drive to fail.

4. Drive Status LED

-  **Solid Green:** The drive is a member of one or more logical drives
-  **Flashing Green:** The drive is rebuilding or performing a RAID migration, strip-size migration, capacity expansion, or logical drive extension or is erasing.
-  **Flashing Amber and Green:** The drive is a member of one or more logical drives and predicts drive failure.
-  **Flashing Amber:** The drive isn't configured and predicts drive failure.
-  **Solid Amber:** The drive has failed.
- **Off:** A RAID controller hasn't configured the drive.

Configuring Integrated Lights Out (iLO) on HPE Apollo 4200 Gen9 Nodes

This section explains how to configure Integrated Lights Out (iLO) on HPE Apollo 4200 Gen9 nodes.

⚠ Important

The HPE Apollo 4200 Gen9 90T, 180T, and 288T platforms will reach their End of Platform Support (EoPS) on April 20, 2025.

Prerequisites

To configure the iLO port, you must have root access to the client-facing network through SSH. For example, you can run the `sudo -s` command.

⚠ Important

Access to the iLO port on a public LAN can have serious security implications because it can grant anyone with credentials direct access to your server's hardware and console. Follow security best practices when implementing iLO access.

How the iLO Port Works

Your node provides iLO support for out-of-band maintenance access even when the node is plugged in but powered off. The following diagram shows the location of the iLO port.

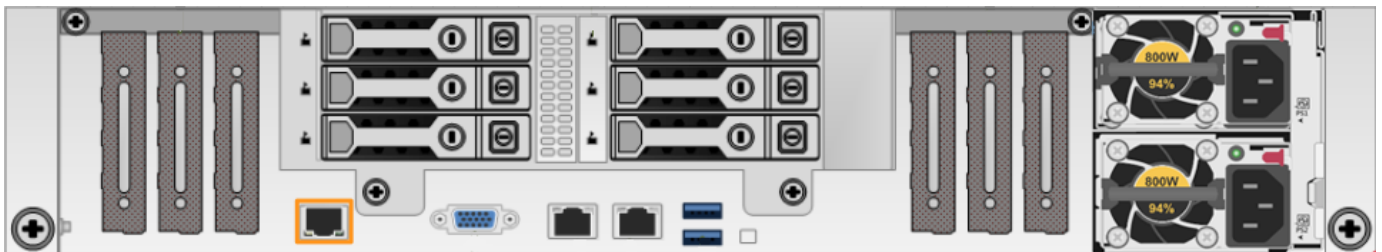

Your nodes receive DHCP address assignments by default. When you configure a node's iLO port, you can access the node by using the IP address (that the DHCP server assigns to the node) and a browser that supports HTML5, Java, or .NET.

⚠ Important

We strongly recommend separating your iLO access network from your client-facing network.

To access iLO configuration from the BIOS System Utilities menu, press F9.

Note

The IMPI username and password are unrelated to your Qumulo administrative credentials.

iLO Configuration

To configure the iLO port, you must use `ipmitool`. For more information, see the following HPE resources:

- [HPE iLO 4 User Guide](#)
- [HPE iLO IPMI User Guide](#)

Replacing Hardware Components in Your HPE Apollo Gen9 Nodes

This section explains how to replace hardware components in HPE Apollo Gen9 nodes.

⚠ Caution

- We strongly recommend engaging an on-site engineer to replace failed hardware components including but not limited to any procedure that:
 - This guide doesn't cover
 - You haven't received training on
 - Requires precautions to avoid damage caused by electrostatic discharge (ESD) by using industry standard anti-static equipment (such as gloves or wrist straps)
- We don't recommend updating firmware on Qumulo-certified hardware nodes unless the equipment manufacturer or a member of the Qumulo Care Team advises you to do so. For questions about this process, [contact the Qumulo Care Team](#).

To Perform the Part Replacement Procedure by Using the FVT

When you replace a component such as the motherboard or a NIC card in your node, you must ensure that the firmware version and configuration are correct for your new components. To do this, you must perform the part replacement procedure by using the FVT.

1. Boot by using the latest version of the Qumulo Core USB Drive Installer.
2. Select **[*] Perform maintenance**.
3. Select **[2] Perform automatic repair after part replacement (non-destructive)**.

The part replacement procedure runs and the **FVT passed!** message appears.

📘 Note

In some cases, after the part replacement procedure, the message **FIX: Run the FVT flash command.** appears. Enter 1 as you would for a fixable issue to reboot the node and then repeat the part replacement procedure.

Replacing a HDD or a SSD Drive

Your HPE Apollo 4200 Gen9 chassis contains 24, 18, or 9 HDD drives and 9, 4, or 3 SSD drives. For more information, see [Front and Rear Drive Bays \(page 73\)](#).

For information about replacing a HDD or SSD drive, see [Storage Drives \(HDD or SSD\)](#) in the HPE documentation.

Replacing the Boot Drive

Your HPE Apollo 4200 Gen9 chassis contains one boot drive. For more information, see [Boot Drive \(page 74\)](#).

Initializing the Replacement Boot Drive

After you replace the boot drive, you must initialize the replacement boot drive by using the Qumulo Core Installer and then rebuild the replacement boot drive by using a script on the node in your cluster.

Step 1: Initialize the Replacement Boot Drive

✓ Tip

To get the correct version of the Qumulo Core Installer for the node in your cluster, [contact the Qumulo Care Team](#)

1. [Create a Qumulo Core USB Drive Installer \(page 10\)](#).
2. Power on your node, enter the boot menu, and select your USB drive.

The Qumulo Core Installer begins to run automatically.

3. When prompted, take the following steps:
 - a. Select `[x] Perform maintenance`.
 - b. Select `[1] Boot drive reset` and then follow the prompts.

The Qumulo Core Installer initializes the boot drive.

4. When the process is complete, the node is powered down automatically.

Step 2: Rebuild the Replacement Boot Drive

1. Power on your node and log in to the node by using the `qq` CLI.
2. To get `root` privileges, run the `sudo qsh` command.
3. To stop the Qumulo Networking Services, run the `service qumulo-networking stop` command.
4. To configure the IP address for the node, run the `ip addr add` command and specify the node's IP address. For example:

```
ip addr add 203.0.113.0/CDR dev bond0
```

5. Ensure that the node can ping other nodes in the cluster.
6. Run the `rebuild_boot_drive.py` script and specify the IP address of *another node* in the cluster, the ID of the node whose boot drive has been replaced, and the password of the administrative account of the cluster. For example:

Note

If your password includes special characters such as the parenthesis (()) or the asterisk (*), use the backslash (\) to escape these characters.

```
/opt/qumulo/rebuild_boot_drive.py \  
  --address 203.0.113.1 \  
  --node-id 2 \  
  --username admin \  
  --password my\ (Special\ *Password
```

Follow the prompts.

7. When the process is complete, reboot the node.

Replacing a Power Supply Unit (PSU)

Your HPE Apollo 4200 Gen9 chassis contains two PSUs.

For information about replacing a PSU, see [Power Supply](#) in the HPE documentation.

Replacing a Fan

Your HPE Apollo 4200 Gen9 chassis has internal fans.

For information about replacing a fan, see [System Fans](#) in the HPE documentation.

Replacing a DIMM

Your HPE Apollo 4200 Gen9 chassis has DIMM slots.

For information about replacing a DIMM, see [DIMM Installation](#) in the HPE documentation.

Note

To identify which DIMM failed, you must use the baseboard management controller (BMC) on the node or another hardware monitoring solution.

HPE Apollo 4200 Gen10

Wiring Nodes and Networking Your HPE Apollo 4200 Gen10 Cluster

This section explains how to wire NIC ports on HPE Apollo 4200 Gen10 nodes and how to network a cluster.

This platform uses a *unified networking configuration* in which the same NIC handles back-end and front-end traffic. In this configuration, each networking port provides communication with clients and between nodes. You can connect the NIC's ports to the same switch or to different switches.

Tip

To identify the eth port, run the following command:

```
for i in /sys/class/net/eth*; \  
do echo $i; \  
cat $i/device/uevent | \  
grep -i pci_slot; \  
done
```

Node NIC and Ports

The following diagrams show the NIC and ports on HPE Apollo 4200 Gen10 nodes.



Prerequisites

- A network switch with the following criteria:
 - Ethernet connection
 - 36T and 90T: 25, 40, or 100 Gbps
 - 192T: 100 Gbps

- 336T: 25 Gbps or 40 Gbps
 - Fully non-blocking architecture
 - IPv6 compatibility
- Compatible network cables
- A sufficient number of ports for connecting all nodes to the same switch fabric
- One static IP for each node, for each defined VLAN

⚠ Important

Before you connect any Qumulo-supported equipment to your network, we strongly recommend consulting with your network engineering team.

Recommended Configuration

- Two redundant switches
- One physical connection to each redundant switch, for each node
- One Link Aggregation Control Protocol (LACP) port-channel for each node with the following configuration:
 - Active mode
 - Slow transmit rate
 - Trunk port with a native VLAN
 - Enabled IEEE 802.3x flow control (full-duplex mode)
- DNS servers
- Network Time Protocol (NTP) server
- Firewall protocol or ports configured for [Qumulo Care Proactive Monitoring](#)
- Where **N** is the number of nodes, up to 10 **N-1** floating IP addresses for each node, for each client-facing VLAN

i Note

The number of floating IP addresses depends on your workflow and on the clients that connect to the cluster, with a minimum of two floating IP addresses for each node, for each client-facing VLAN, but with no more than ten floating IP addresses for each node, for each client-facing VLAN.

- Nodes connected at their maximum Ethernet speed (this ensures advertised performance). To avoid network bottlenecks, Qumulo validates system performance with

this configuration by using clients connected at the same link speed and to the same switch as the nodes.

Connecting to Redundant Switches

This section explains how to connect a four-node HPE cluster to dual switches for redundancy. We recommend this configuration for HPE hardware. If either switch becomes inoperative, the cluster remains accessible through the remaining switch.

- Connect the two 25 Gbps, 40 Gbps, or 100 Gbps ports on the nodes to separate switches.
- Use at least one port on both switches as an uplink to the client network. To ensure an acceptable level of physical network redundancy and to meet the necessary client access throughput rates, use an appropriate combination of 10 Gbps, 25 Gbps, 40 Gbps, or 100 Gbps network uplinks.
- Use at least one peer link between the switches.

Connecting to a Single Switch

This section explains how to connect a four-node HPE cluster to a single switch.

i Note

If the switch becomes inoperative, the cluster becomes inaccessible.

- Connect two 25 Gbps, 40 Gbps, or 100 Gbps ports to the switch.
- Connect any uplink ports to the client network.

Creating and Configuring a Qumulo Cluster with HPE Apollo 4200 Gen10 Nodes

This section explains how to prepare HPE Apollo 4200 Gen10 nodes for creating a Qumulo cluster. This guide is for system administrators, professional service providers, and colleagues in your organization who are responsible for installing and configuring server hardware.

Prerequisites

[Qumulo Core USB Drive Installer](#)

Step 1: Verify Your Node

1. Shut down your node and connect a display, a keyboard, and a mouse to it.
2. Plug the [Qumulo Core USB Drive Installer](#) into an available USB port on the node and then press the power button.
3. On the HPE ProLiant boot screen, do one of the following:
 - If the **Boot Mode: Legacy BIOS** message appears, skip the rest of this section and continue to [boot by using the Qumulo Core USB Drive Installer \(page 91\)](#).
 - If the **Boot Mode: Legacy BIOS** message doesn't appear, press F9.
4. On the System Utilities page, click System Configuration > BIOS/Platform Configuration (RBSU) > Boot Options.
5. On the Boot Options page, set **Boot Mode** to **Legacy BIOS Mode** and then press F10.
6. Press Esc until you return to the main page.
7. Click **Reboot the System**.

Step 2: Boot by Using the Qumulo Core USB Drive Installer

1. On the HPE ProLiant boot screen, press F11.

Note

The **Boot Menu** page might take a few minutes to appear.

2. On the **Boot Menu** page, to boot into the **Legacy BIOS One-Time Boot Menu**, press Enter.
3. In the **Question** dialog box, click **OK**.
4. From the **Default Boot Override Options** menu, select **2) One Time Boot to USB DriveKey**.

Step 3: Run the Field Verification Tool (FVT)

After the node reboots, the Field Verification Tool runs automatically.

Select [1] Factory reset (DESTROYS ALL DATA) and then enter **DESTROY ALL DATA**.

Fixable Issues During Installation

If the FVT finds fixable issues, it prompts you to auto-correct any detected issues, depending on your installation scenario. Issues that the FVT can auto-correct include the following:

- BIOS Configuration
 - Drive firmware
 - Drive controller firmware
 - NIC mode for CX5
 - Boot order
1. To attempt auto-correction, select [1] Run FVT Flash. This will try to fix issues then reboot.
If the fixes are successful, the FVT reboots the node automatically.
 2. To re-attempt verification, [boot by using the Qumulo Core USB Drive Installer \(page 91\)](#) and then continue the installation.

Non-Fixable Issues

If the FVT is unable to auto-correct any issues, the message **Not fixable issues were detected.** appears, providing reasons for failure.

For help with troubleshooting your node, [contact the Qumulo Care Team](#).

Step 4: Install Qumulo Core by Using the USB Drive Installer

⚠ Caution

Store your master key in a secure location. If you lose your master key, you might not be able to recover your data from certain hardware failures.

Perform the following steps on every node in your cluster.

1. Do one of the following:
 - Choose [1] Install Qumulo Core without HPE Hardware encryption
 - Choose [2] Install Qumulo Core with HPE Hardware encryption.
2. If you install Qumulo Core with encryption, enter your cryptographic login password and master encryption key.

Note

- Your login password must be 8-16 characters long and must contain at least:
 - One uppercase character
 - One lowercase character
 - One numeric character
 - One symbol (such as # or \$)
- Your encryption master key must be 10-32 characters long.
- Both your login password and encryption master key:
 - Can use uppercase and lowercase letters, numbers, and symbols
 - Must use only ASCII characters
 - Must not use spaces, semicolons (;), or quotation marks (")
- Store your master key in a secure location for the lifetime of the cluster.

Step 5: Create and Configure Your Cluster

1. Review the End User Agreement, click I agree to the End User Agreement, and then click Submit.
2. Name your cluster.
3. On the 1. Set up cluster page, select the nodes to add to your cluster.

As you select nodes, the installer updates the total capacity of your cluster at the bottom of the page.

Note

If any nodes are missing, confirm that they are powered on and connected to the same network.

4. Confirm that the individual nodes have the expected capacity.
5. On the 2. Confirm cluster protection level page, Qumulo Core selects the recommended 2, 3, or 4-drive protection level based on your cluster size and node type.
6. If the Customize Protection Level option appears, you can increase your system resilience by selecting 3- or 4-drive protection.

⚠ Important

- Qumulo Core 6.1.0.1 and 6.1.1 support Adaptive Data Protection by letting you reconfigure your cluster's fault tolerance level and storage efficiency only when you add nodes to your cluster.

Depending on your cluster, Qumulo Core shows configuration options that offer better fault tolerance levels, better storage efficiency, or both benefits. To enable Adaptive Data Protection for your cluster, you must [contact the Qumulo Care Team](#).

- In Qumulo Core 6.1.2 (and higher), you can change your cluster's data protection configuration when you add or replace nodes by using the `qq` CLI.
- Using 3- or 4-drive protection reduces the total capacity of your cluster.

7. Enter a password for the administrative account and click **Create Cluster**.
8. To access the Qumulo Core Web UI, connect to any node by entering its IP address into a browser.

Front and Rear Drive Bays on HPE Apollo 4200 Gen10 Nodes

This section shows the front large form factor (LFF) and rear small form factor (SFF) drive bays in HPE Apollo 4200 Gen10 nodes.

Front LFF Drive Row



Second LFF Drive Row

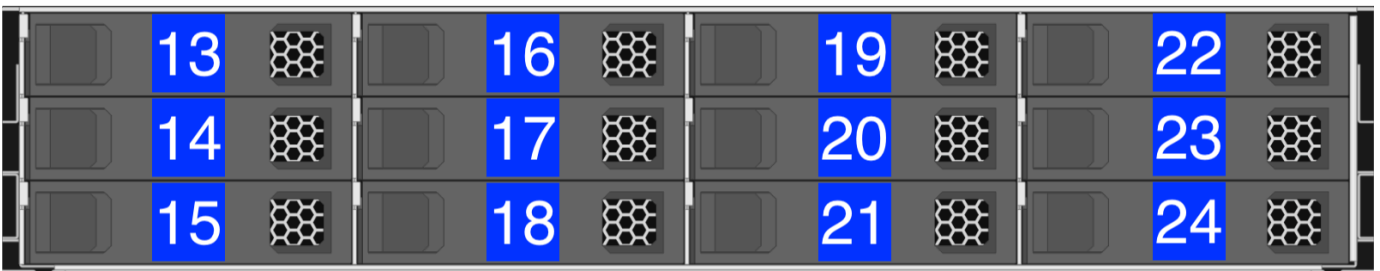

Rear SFF Hot-Plug Drives

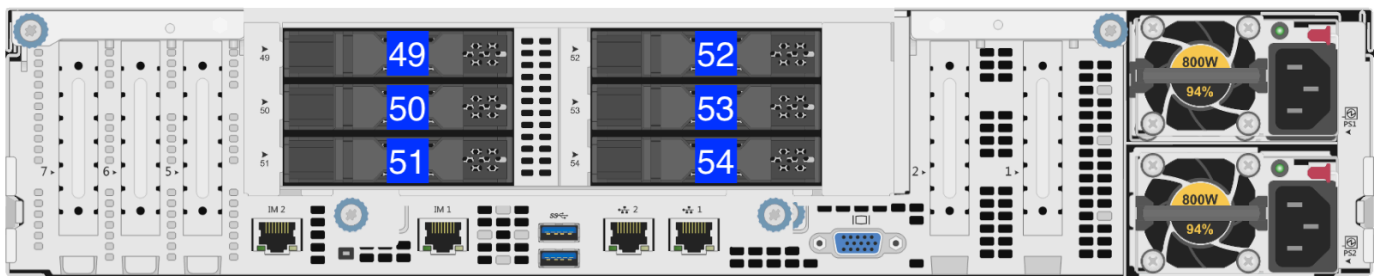

Boot Drive

⚠ Important

Before you remove the boot drive [contact the Qumulo Care Team](#) for additional instructions.

36T and 90T Nodes

In 36T and 90T nodes, the boot drive is located in the second LFF drive row.

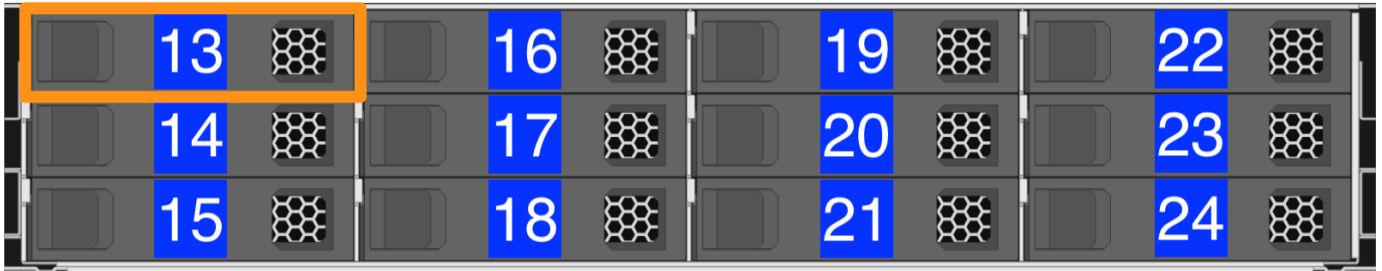

192T Nodes

In 192T nodes, the boot drive is a BOSS PCIe riser card.

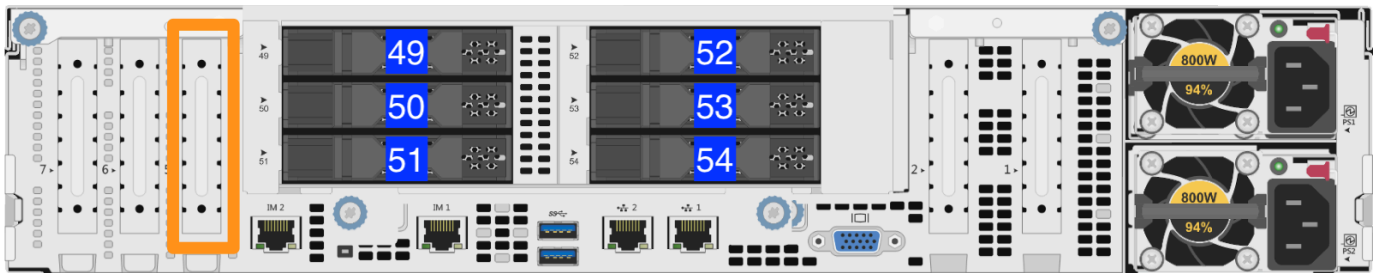

336T Nodes

In 336T nodes, the boot drive is located with the rear SFF hot-plug drives.

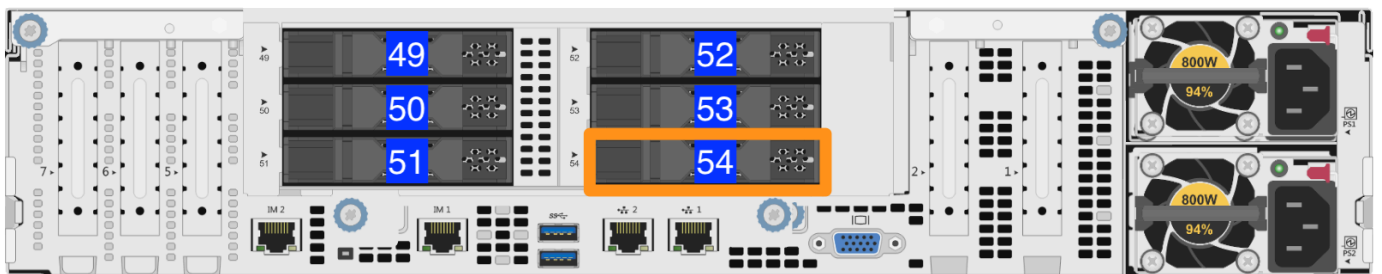

Panel LEDs on HPE Apollo 4200 Gen10 Nodes



This section explains the LEDs on HPE Apollo 4200 Gen10 nodes, including front panel LEDs and buttons, power fault LEDs, and rear panel LEDs. You can use these LEDs to diagnose hardware health issues.

Front Panel LEDs and Buttons

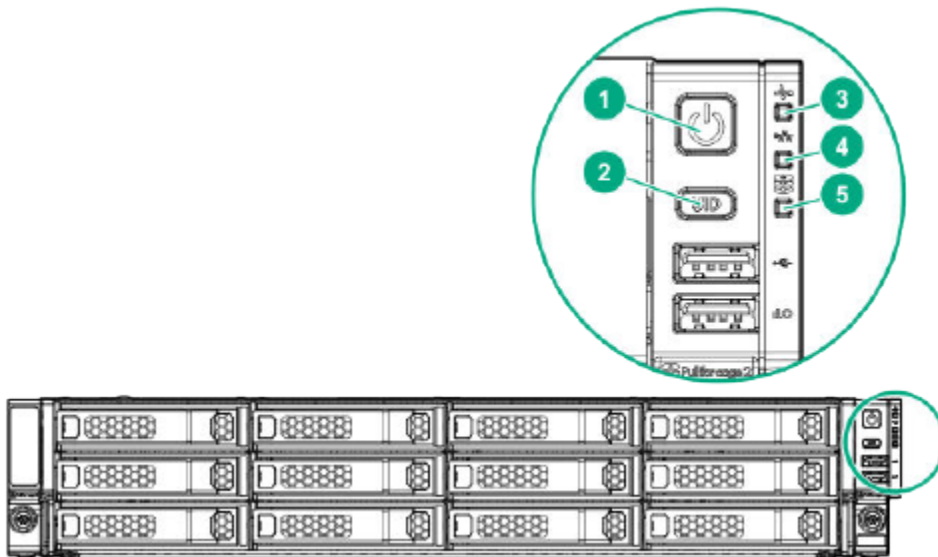

To locate the front panel LEDs, use the following diagram.



1. Power On or Standby Button and System Power LED





-  Solid Green: System on
-  Flashing Green: (1 flash each second) Performing power-on sequence
-  Solid Amber: System in standby
- Off: No power present

2. UID Button and LED

-  Solid Blue: Activated
-  Flashing Blue:
 - 1 flash each second: Remote management or firmware upgrade in progress
 - 4 flashes each second: iLO manual reboot sequence initiated
 - 8 flashes each second: iLO manual reboot sequence in progress

- Off: Deactivated



3. Health LED

-  Solid Green: Normal
-  Flashing Green: (1 flash each second) iLO is rebooting
-  Flashing Amber: System degraded
-  Flashing Red: (1 flash each second) System critical



i Note

If the Health LED indicates a degraded or critical state, review the system integrated management log (IML) or use iLO to review the system health status.

4. NIC Status LED

-  Solid Green: Link to network
-  Flashing Green: (1 flash each second) Network active
- Off: No network activity

5. Front Drive Health or Thermal LED

-  Solid Green: Drives which the SAS expander supports are functional. This applies to all front drives and the rear drives connected to the front drive cage 2 backplane.
-  Solid Amber: Failure or predictive failure of one or more drives that the SAS expander supports. This applies to all front drives and to the rear drives connected to the front drive cage 2 backplane.
-  Flashing Amber: (1 flash each second) The temperature sensor in one or more front drives is about to reach the thermal threshold. You must immediately slide the front drive cages back into the chassis and keep them there until the LED turns green.

i Note

This LED behavior depends on the iLO 08-HD Max sensor reading.

- Off: No power present

Note

If the (5) Front Drive Health or Thermal LED, or the (1) Power On or Standby Button and System Power LED are off, one of the following conditions is possible:

- Facility power not present
- Power cord detached
- No power supplies installed
- Power supply failure
- Front I/O cable disconnected

Power Fault LEDs

If the (1) Power On or Standby Button and System Power LED, (2) UID Button and LED, (3) Health LED, and (4) NIC Status LED flash simultaneously, a power fault has occurred. The following table lists the LED behavior corresponding to affected subsystems.

Number of LED Flashes	Affected Subsystem
1	System board
2	Processor
3	Memory
4	Riser board PCIe slots
5	FlexibleLOM
6	Removable HPE Flexible Smart Array controller or Smart SAS HBA controller
7	System board PCIe slots
8	Power backplane or storage backplane
9	Power supply

Rear Panel LEDs

To locate the rear panel LEDs, use the following diagram.

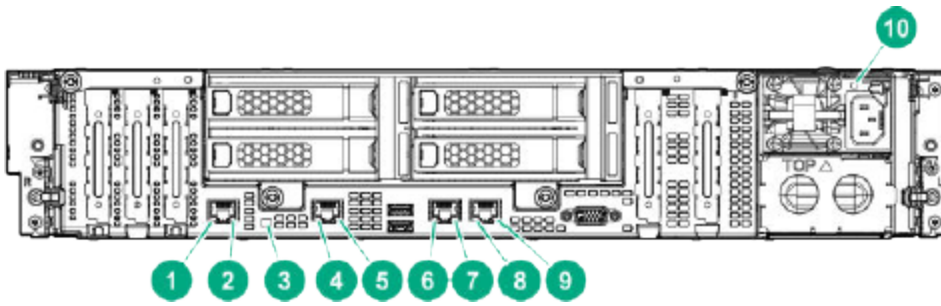

1. Dedicated iLO Port 1 Link LED

- ● Green: Network link
- Off: No network link

2. Dedicated iLO Port 1 Activity LED

- ● Solid Green: Link to network
- ● Flashing Green: Network active
- Off: No network activity

3. UID LED

- ● Solid Blue: Activated
- ● Flashing Blue:
 - 1 flash each second: Remote management or firmware upgrade in progress
 - 4 flashes each second: iLO manual reboot sequence initiated
 - 8 flashes each second: iLO manual reboot sequence in progress

4. Dedicated iLO Port 2 Link LED

- ● Green: Network link
- Off: No network link

5. Dedicated iLO Port 2 Activity LED



- ● Solid Green: Link to network
- ● Flashing Green: Network active
- Off: No network activity

6. NIC Port 1 Link LED

- ● Green: Network link

- Off: No network link



7. NIC Port 1 Activity LED

-  Solid Green: Link to network
-  Flashing Green: Network active
- Off: No network activity

8. NIC Port 2 Link LED

-  Green: Network link
- Off: No network link

9. NIC Port 2 Activity LED

-  Solid Green: Link to network
-  Flashing Green: Network active
- Off: No network activity

10. Power Supply LED

-  Solid Green: Normal
- Off: One or more of the following conditions exist:
 - Power unavailable
 - Power supply failed
 - Power supply in standby mode
 - Power supply error

Drive LEDs on HPE Apollo 4200 Gen10 Nodes



This section explains the LEDs on large form factor (LFF) and small form factor (SFF) drives in HPE Apollo 4200 Gen10 nodes.

Large Form Factor (LFF) Drive LEDs

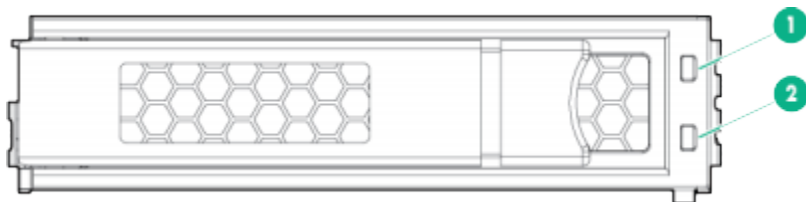
To locate the LFF drive LEDs, use the following diagram.



You can determine the current state of an LFF drive by reviewing the status of the following LEDs:

1. Fault or UID LED
 -  Amber
 -  Blue
2. Online or Activity LED
 -  Green

The following table explains the various combinations of the two LFF LEDs.

Online or Activity LED	Fault or UID LED	Description
On, off, or flashing	Alternating amber and blue	One or more of the following conditions exist: <ul style="list-style-type: none">• The drive has failed.• This system received a predictive failure alert about the drive.• A management application has selected the drive.
On, off, or flashing	Solid blue	One or more of the following conditions exist: <ul style="list-style-type: none">• The drive is operating normally.• A management application has selected the drive.

Online or Activity LED	Fault or UID LED	Description
On	Flashing amber	This system received a predictive failure alert about the drive. Replace the drive as soon as possible.
On	Off	The drive is online but isn't active currently.
1 flash each second	Flashing amber	Don't remove the drive. Removing the drive might terminate the current operation and cause data loss. The drive is part of an array that is undergoing capacity expansion or stripe migration. However, the system received a predictive failure alert about the drive. To minimize the risk of data loss, don't remove the drive until the expansion or migration is complete.
1 flash each second	Off	Don't remove the drive. Removing the drive might terminate the current operation and cause data loss. The drive is rebuilding, erasing, or is part of an array that is undergoing capacity expansion or stripe migration.
4 flashes each second	Flashing amber	The drive is active but it received a predictive failure alert. Replace the drive as soon as possible.
4 flashes each second	Off	The drive is active and is operating normally.
Off	Solid amber	The drive has a critical fault condition and the controller has placed it offline. Replace the drive as soon as possible.
Off	Flashing amber	This system received a predictive failure alert about the drive. Replace the drive as soon as possible.
Off	Off	The drive is offline, a spare, or isn't configured as part of an array.

Small Form Factor (SFF) Drive LEDs

To locate the SFF drive LEDs, use the following diagram.

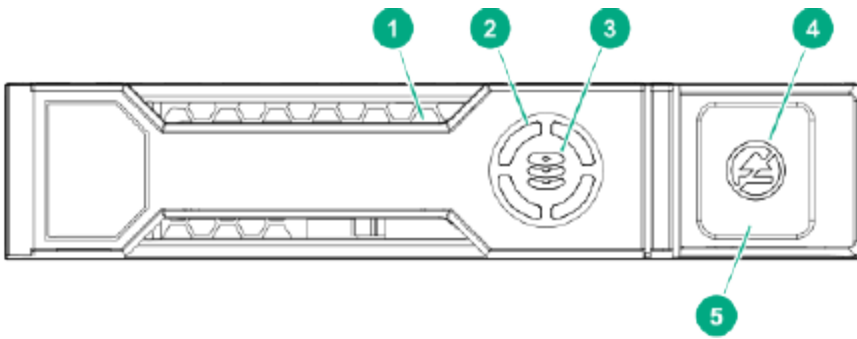

1. Locate LED

- ● **Solid Blue:** A host application is identifying the drive.
- ● **Flashing Blue:** The drive carrier firmware is updating or requires an update.

i Note

The Locate LED is behind the release lever. When it is illuminated, it is visible.

2. Activity Ring LED

- ● **Rotating Green:** Drive activity
- **Off:** No drive activity

3. Drive Status LED

- ● **Solid Green:** The drive is a member of one or more logical drives
- ● **Flashing Green:** The drive is rebuilding or performing a RAID migration, strip-size migration, capacity expansion, or logical drive extension or is erasing.
- ● ● **Flashing Amber and Green:** The drive is a member of one or more logical drives and predicts drive failure.
- ● **Flashing Amber:** The drive isn't configured and predicts drive failure.
- ● **Solid Amber:** The drive has failed.
- **Off:** A RAID controller hasn't configured the drive.

4. Don't Remove LED

- ○ **Solid White:** Don't remove the drive. Removing the drive causes one or more of the logical drives to fail.
- **Off:** Removing the drive doesn't cause a logical drive to fail.

5. Don't Remove Button

To open the carrier, press the release lever.

Configuring Integrated Lights Out (iLO) on HPE Apollo 4200 Gen10 Nodes

This section explains how to configure Integrated Lights Out (iLO) on HPE Apollo 4200 Gen10 nodes.

Prerequisites

To configure the iLO port, you must have root access to the client-facing network through SSH. For example, you can run the `sudo -s` command.

⚠ Important

Access to the iLO port on a public LAN can have serious security implications because it can grant anyone with credentials direct access to your server's hardware and console. Follow security best practices when implementing iLO access.

How the iLO Port Works

Your node provides iLO support for out-of-band maintenance access even when the node is plugged in but powered off. The following diagram shows the location of the iLO port.



Your nodes receive DHCP address assignments by default. When you configure a node's iLO port, you can access the node by using the IP address (that the DHCP server assigns to the node) and a browser that supports HTML5, Java, or .NET.

⚠ Important

We strongly recommend separating your iLO access network from your client-facing network.

To access iLO configuration from the BIOS System Utilities menu, press F9.

📘 Note

The IMPI username and password are unrelated to your Qumulo administrative credentials.

iLO Configuration

To configure the iLO port, you must use `ipmitool`. For more information, see the following HPE resources:

- [HPE iLO 5 User Guide](#)
- [HPE iLO IPMI User Guide](#)

Replacing Hardware Components in Your HPE Apollo 4200 Gen10 Nodes

This section explains how to replace hardware components in HPE Apollo 4200 Gen10 nodes.

⚠ Caution

- We strongly recommend engaging an on-site engineer to replace failed hardware components including but not limited to any procedure that:
 - This guide doesn't cover
 - You haven't received training on
 - Requires precautions to avoid damage caused by electrostatic discharge (ESD) by using industry standard anti-static equipment (such as gloves or wrist straps)
- We don't recommend updating firmware on Qumulo-certified hardware nodes unless the equipment manufacturer or a member of the Qumulo Care Team advises you to do so. For questions about this process, [contact the Qumulo Care Team](#).

To Perform the Part Replacement Procedure by Using the FVT

When you replace a component such as the motherboard or a NIC card in your node, you must ensure that the firmware version and configuration are correct for your new components. To do this, you must perform the part replacement procedure by using the FVT.

1. Boot by using the latest version of the Qumulo Core USB Drive Installer.
2. Select **[*] Perform maintenance**.
3. Select **[2] Perform automatic repair after part replacement (non-destructive)**.

The part replacement procedure runs and the **FVT passed!** message appears.

ℹ Note

In some cases, after the part replacement procedure, the message **FIX: Run the FVT flash command.** appears. Enter 1 as you would for a fixable issue to reboot the node and then repeat the part replacement procedure.

Replacing an HDD or SSD Drive

Your HPE Apollo 4200 Gen10 chassis contains either 24 or 9 HDD drives and 6, 4, or 3 SSD drives. For more information, see [Front and Rear Drive Bays \(page 95\)](#).

For information about replacing an HDD or SSD drive, see [Removing and Replacing a Hot-Plug Drive](#) in the HPE documentation.

Replacing an M.2 Boot Drive

Your HPE Apollo 4200 Gen10 chassis contains one boot drive on a riser card. For more information, see [Boot Drive \(page 95\)](#).

For information about replacing an NVMe M.2 boot drive, see [Removing and Replacing the Boot Device](#) in the HPE documentation.

Initializing the Replacement Boot Drive

After you replace the boot drive, you must initialize the replacement boot drive by using the Qumulo Core Installer and then rebuild the replacement boot drive by using a script on the node in your cluster.

Step 1: Initialize the Replacement Boot Drive

✓ Tip

To get the correct version of the Qumulo Core Installer for the node in your cluster, [contact the Qumulo Care Team](#)

1. [Create a Qumulo Core USB Drive Installer \(page 10\)](#).
2. Power on your node, enter the boot menu, and select your USB drive.

The Qumulo Core Installer begins to run automatically.

3. When prompted, take the following steps:
 - a. Select `[x] Perform maintenance`.
 - b. Select `[1] Boot drive reset` and then follow the prompts.

The Qumulo Core Installer initializes the boot drive.

4. When the process is complete, the node is powered down automatically.

Step 2: Rebuild the Replacement Boot Drive

1. Power on your node and log in to the node by using the `qq` CLI.
2. To get `root` privileges, run the `sudo qsh` command.
3. To stop the Qumulo Networking Services, run the `service qumulo-networking stop` command.
4. To configure the IP address for the node, run the `ip addr add` command and specify the node's IP address. For example:

```
ip addr add 203.0.113.0/CDR dev bond0
```

5. Ensure that the node can ping other nodes in the cluster.
6. Run the `rebuild_boot_drive.py` script and specify the IP address of *another node* in the cluster, the ID of the node whose boot drive has been replaced, and the password of the administrative account of the cluster. For example:

Note

If your password includes special characters such as the parenthesis (()) or the asterisk (*), use the backslash (\) to escape these characters.

```
/opt/qumulo/rebuild_boot_drive.py \  
  --address 203.0.113.1 \  
  --node-id 2 \  
  --username admin \  
  --password my\ (Special\ *Password
```

Follow the prompts.

7. When the process is complete, reboot the node.

Replacing a Power Supply Unit (PSU)

Your HPE Apollo 4200 Gen10 chassis contains two PSUs.

For information about replacing a PSU, see [Removing and Replacing a Power Supply](#) in the HPE documentation.

Replacing a Fan

Your HPE Apollo 4200 Gen10 chassis has internal fans.

For information about replacing a fan, see [Removing and Replacing a Fan](#) in the HPE documentation.

Replacing a DIMM

Your HPE Apollo 4200 Gen10 chassis has DIMM slots.

For information about replacing a DIMM, see [Removing and Replacing a DIMM](#) in the HPE documentation.

i Note

To identify which DIMM failed, you must use the baseboard management controller (BMC) on the node or another hardware monitoring solution.

HPE Apollo 4200 Gen10 Plus

Wiring Nodes and Networking Your HPE Apollo 4200 Gen10 Plus Cluster

This section explains how to wire NIC ports on HPE Apollo 4200 Gen10 Plus nodes and how to network a cluster.

This platform uses a *unified networking configuration* in which the same NIC handles back-end and front-end traffic. In this configuration, each networking port provides communication with clients and between nodes. You can connect the NIC's ports to the same switch or to different switches.

✓ Tip

To identify the eth port, run the following command:

```
for i in /sys/class/net/eth*; \  
do echo $i; \  
cat $i/device/uevent | \  
grep -i pci_slot; \  
done
```

Node NIC and Ports

The following diagrams show the NIC and ports on HPE Apollo 4200 Gen10 Plus node types.

Back
480 TB and 240 TB (General Purpose)
90TB and 36TB (Active)

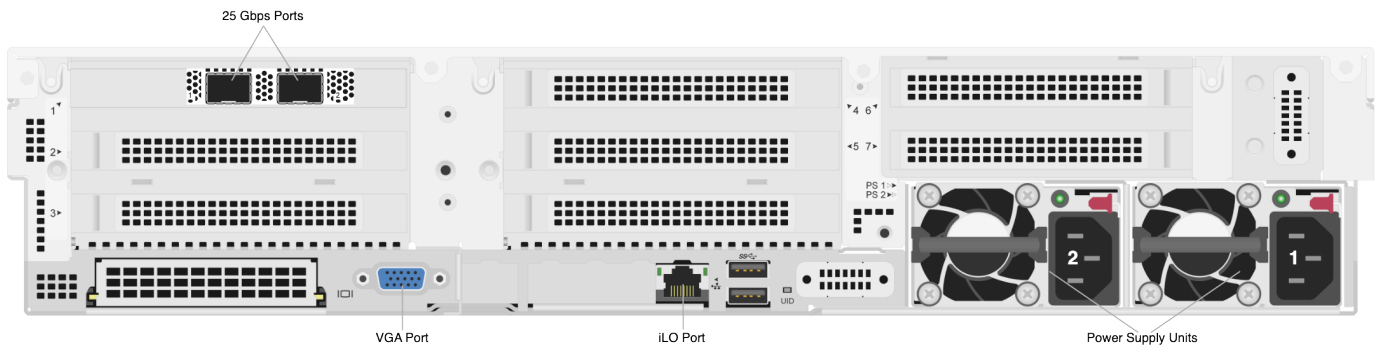

Back
480 TB and 240 TB (Active)

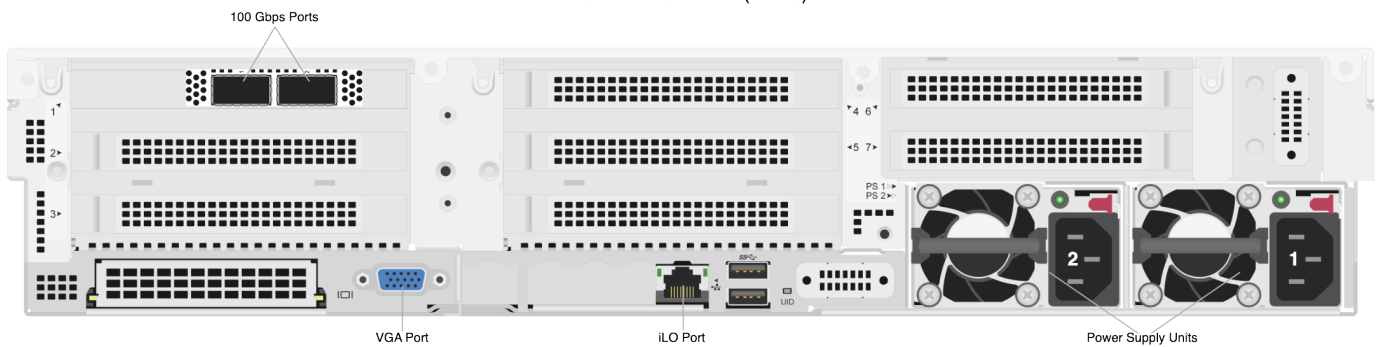

Tip

To identify the eth port, run the following command:

```
for i in /sys/class/net/eth*; \  
do echo $i; \  
cat $i/device/uevent | \  
grep -i pci_slot; \  
done
```

Prerequisites

Note

Before you create your Qumulo cluster, if your client environment requires Jumbo Frames (9,000 MTU), configure your switch to support a higher MTU.

Your node requires the following resources.

- A network switch with the following specifications:

- Ethernet connectivity
- Fully non-blocking architecture
- IPv6 capability
- Compatible networking cables
- A sufficient number of ports for connecting all nodes to the same switch fabric
- One static IP for each node, for each defined VLAN

Recommended Configuration

This platform uses a *unified networking configuration* in which the same NIC handles back-end and front-end traffic. In this configuration, each networking port provides communication with clients and between nodes. You can connect the NIC's ports to the same switch or to different switches. However, for greater reliability, we recommend connecting both ports on every node to each switch.

We recommend the following configuration for your node.

- Your Qumulo MTU configured to match your client environment
- Two physical connections for each node, one connection for each redundant switch
- One Link Aggregation Control Protocol (LACP) port-channel for each network on each node, with the following configuration
 - Active mode
 - Slow transmit rate
 - Access port or trunk port with a native VLAN
- DNS servers
- A Network Time Protocol (NTP) server
- Firewall protocols or ports allowed for proactive monitoring
- Where **N** is the number of nodes, **N-1** floating IP addresses for each node, for each client-facing VLAN

Connecting to Redundant Switches

For redundancy, we recommend connecting your cluster to dual switches. If either switch becomes inoperative, the cluster is still be accessible from the remaining switch.

- Connect the two NIC ports on your nodes to separate switches.
- The uplinks to the client network must equal the bandwidth from the cluster to the switch.

- The two ports form an LACP port channel by using a multi-chassis link aggregation group.
- Use an appropriate inter-switch link or virtual port channel.

Connecting to a Single Switch

You can connect a your cluster to a single switch. If this switch becomes inoperative, the entire cluster becomes inaccessible.

- Connect the two NIC ports on your nodes to a single switch.
- The uplinks to the client network must equal the bandwidth from the cluster to the switch.
- The two ports form an LACP port channel.

Four-Node Cluster Architecture Diagram

The following is the recommended configuration for a four-node cluster connected to an out-of-band management switch and redundant switches.

Management LAN Ports
Connect to Out-of-Band
Management Switch

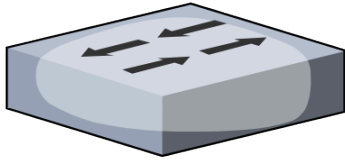

Out-of-Band
Management Switch

Ports Acting as Front-End and Back-End
Connect to Redundant Switches

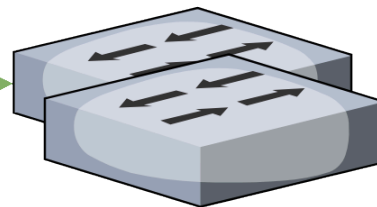
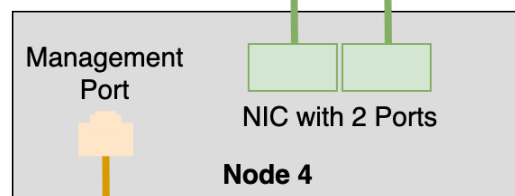
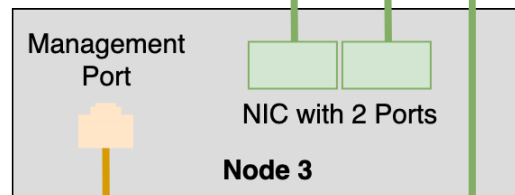
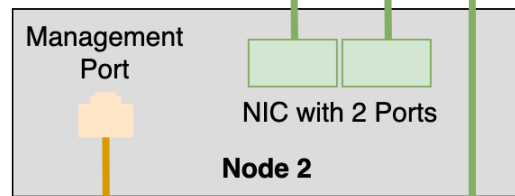
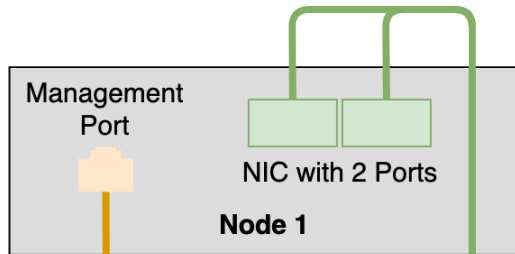

Redundant Switches
Connect to Local Network
and Connect Nodes Together

⚠ Important

For your node to work correctly, you must connect at least one port in the NIC.

Creating and Configuring a Qumulo Cluster with HPE Apollo 4200 Gen10 Plus Nodes

This section explains how to prepare HPE Apollo 4200 Gen10 Plus nodes for creating a Qumulo cluster. This guide is for system administrators, professional service providers, and colleagues in your organization who are responsible for installing and configuring server hardware.

Prerequisites

[Qumulo Core USB Drive Installer](#)

Step 1: Verify Your Node

1. Shut down your node and connect a display, a keyboard, and a mouse to it.
2. Plug the [Qumulo Core USB Drive Installer](#) into an available USB port on the node and then press the power button.

Step 2: Boot by Using the Qumulo Core USB Drive Installer

1. On the HPE ProLiant boot screen, press F11.

Note

The **Boot Menu** page might take a few minutes to appear.

2. On the **One-Time Boot Menu** page, click **Generic USB Boot** and continue to run the Field Verification Tool (FVT).

Step 3: Run the Field Verification Tool (FVT)

After the node reboots, the Field Verification Tool runs automatically.

Select **[1] Factory reset (DESTROYS ALL DATA)** and then enter **DESTROY ALL DATA**.

Fixable Issues During Installation

If the FVT finds fixable issues, it prompts you to auto-correct any detected issues, depending on your installation scenario. Issues that the FVT can auto-correct include the following:

- BIOS Configuration
- Drive firmware
- Drive controller firmware
- NIC mode for CX5
- Boot order

1. To attempt auto-correction, select [1] Run FVT Flash. This will try to fix issues then reboot.
If the fixes are successful, the FVT reboots the node automatically.
2. To re-attempt verification, [boot by using the Qumulo Core USB Drive Installer \(page 116\)](#) and then continue the installation.

Non-Fixable Issues

If the FVT is unable to auto-correct any issues, the message **Not fixable issues were detected.** appears, providing reasons for failure.

For help with troubleshooting your node, [contact the Qumulo Care Team](#).

Step 4: Create and Configure Your Cluster

1. Review the **End User Agreement**, click **I agree to the End User Agreement**, and then click **Submit**.
2. Name your cluster.
3. On the **1. Set up cluster** page, select the nodes to add to your cluster.

As you select nodes, the installer updates the total capacity of your cluster at the bottom of the page.

Note

If any nodes are missing, confirm that they are powered on and connected to the same network.

4. Confirm that the individual nodes have the expected capacity.
5. On the **2. Confirm cluster protection level** page, Qumulo Core selects the recommended 2, 3, or 4-drive protection level based on your cluster size and node type.
6. If the **Customize Protection Level** option appears, you can increase your system resilience by selecting 3- or 4-drive protection.

⚠ Important

- Qumulo Core 6.1.0.1 and 6.1.1 support Adaptive Data Protection by letting you reconfigure your cluster's fault tolerance level and storage efficiency only when you add nodes to your cluster.

Depending on your cluster, Qumulo Core shows configuration options that offer better fault tolerance levels, better storage efficiency, or both benefits. To enable Adaptive Data Protection for your cluster, you must [contact the Qumulo Care Team](#).

- In Qumulo Core 6.1.2 (and higher), you can change your cluster's data protection configuration when you add or replace nodes by using the `qq` CLI.
- Using 3- or 4-drive protection reduces the total capacity of your cluster.

7. Enter a password for the administrative account and click **Create Cluster**.
8. To access the Qumulo Core Web UI, connect to any node by entering its IP address into a browser.

Front and Internal Drive Bays on HPE Apollo 4200 Gen10 Plus Nodes

This section shows the front large form factor (LFF), internal LFF, and internal small form factor (SFF) drive bays in HPE Apollo 4200 Gen10 Plus nodes.

480TB and 240TB Nodes

In 480TB and 240TB nodes, all drive bays are populated.

Front LFF Drive Row

The following diagram shows the front LFF drive row, or cage 1. Cage 1 holds the first half of the drives in box 1, bays 1-12.



Internal LFF Drive Row

The internal LFF drive row, or cage 2, flips up behind the front drive row in the node. Cage 2 holds the second half of the drives in box 1, bays 13-24.

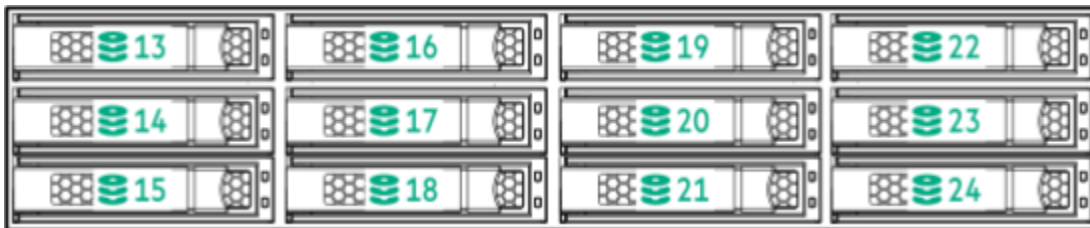

Internal SFF Drive Row

The internal SFF drive row flips up behind the internal LFF drive row. This row holds box 3, bays 1-8.



90TB and 36TB Nodes

In 90TB and 36TB Nodes, some drive bays are empty.

Note

In the following diagrams, empty drive bays appear in gray.

Front LFF Drive Row

The following diagram shows the front LFF drive row, or cage 1. Cage 1 holds the drives in box 1, bays 1-9. Bays 10-12 are empty.



Internal LFF Drive Row

The internal LFF drive row, or cage 2, flips up behind the front drive row in the node. Bays 13-24 in cage 2, box 1 are empty.



Internal SFF Drive Row

The internal SFF drive row flips up behind the internal LFF drive row. Bays 1-4 and 8 in box 3 are empty.



Boot Drive

Important

Before you remove the boot drive [contact the Qumulo Care Team](#) for additional instructions.

The boot drive is located inside the node at the indicated location. The drive is mounted onto a PCI Express slot and connected to the motherboard with a SATA cable.

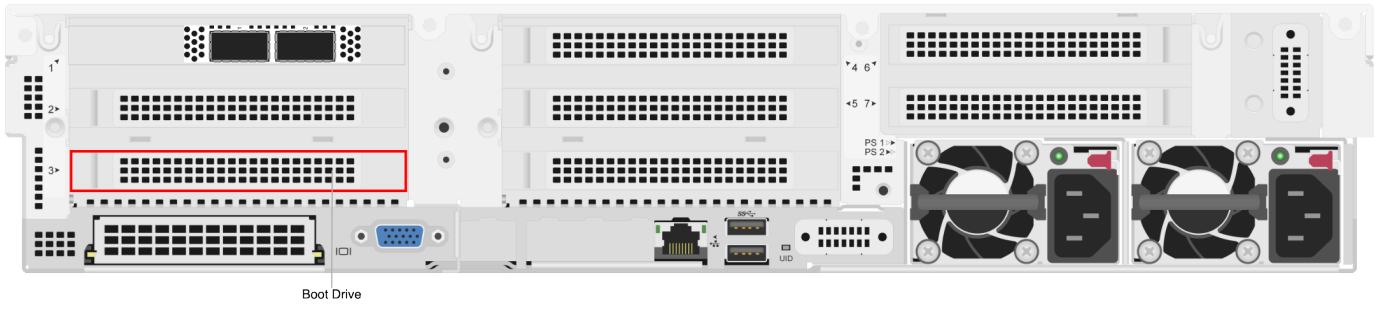

Panel LEDs on HPE Apollo 4200 Gen10 Plus Nodes

This section explains the LEDs on HPE Apollo 4200 Gen10 Plus nodes, including front panel LEDs and buttons, power fault LEDs, and rear panel LEDs. You can use these LEDs to diagnose hardware health issues.

Front Panel LEDs and Buttons

The following diagram shows the LEDs and buttons on the front panel.

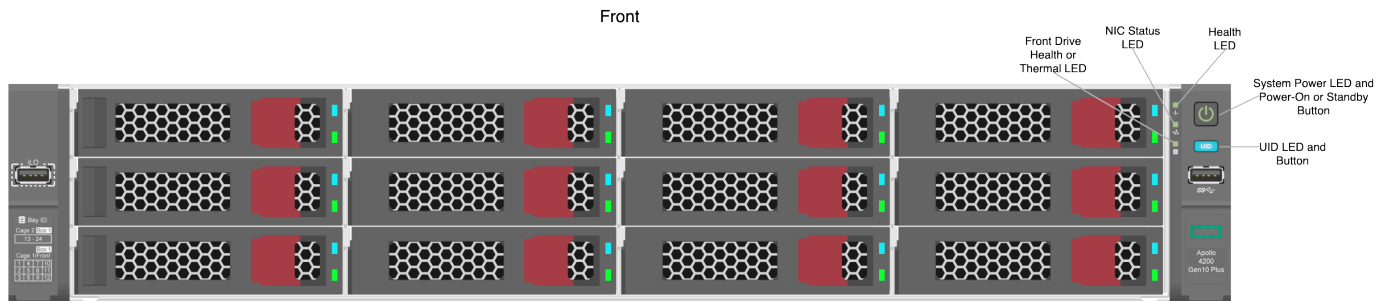

Rear Panel LEDs

The following diagram shows the LEDs on the rear panel.

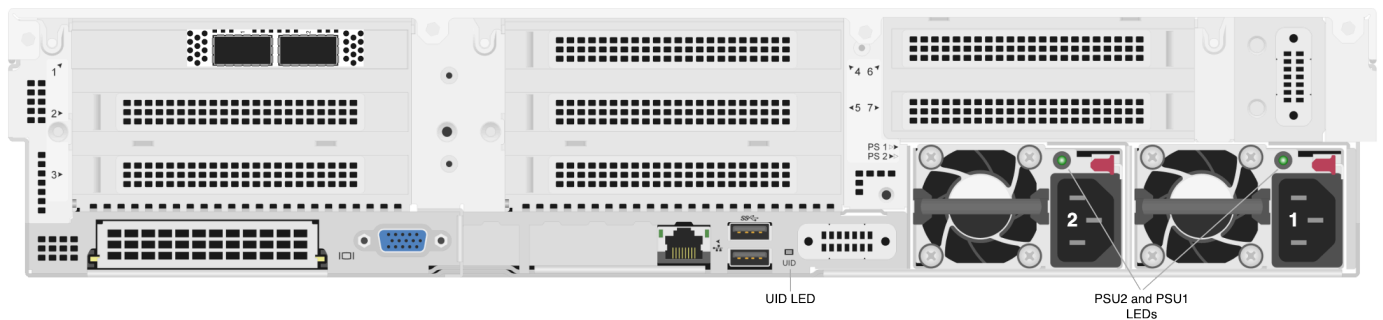

Configuring Integrated Lights Out (iLO) on HPE Apollo 4200 Gen10 Plus Nodes

This section explains how to configure Integrated Lights Out (iLO) on HPE Apollo 4200 Gen10 Plus nodes.

Prerequisites

To configure the iLO port, you must have root access to the client-facing network through SSH. For example, you can run the `sudo -s` command.

⚠ Important

Access to the iLO port on a public LAN can have serious security implications because it can grant anyone with credentials direct access to your server's hardware and console. Follow security best practices when implementing iLO access.

How the iLO Port Works

Your node provides iLO support for out-of-band maintenance access even when the node is plugged in but powered off. The following diagram shows the location of the iLO port.

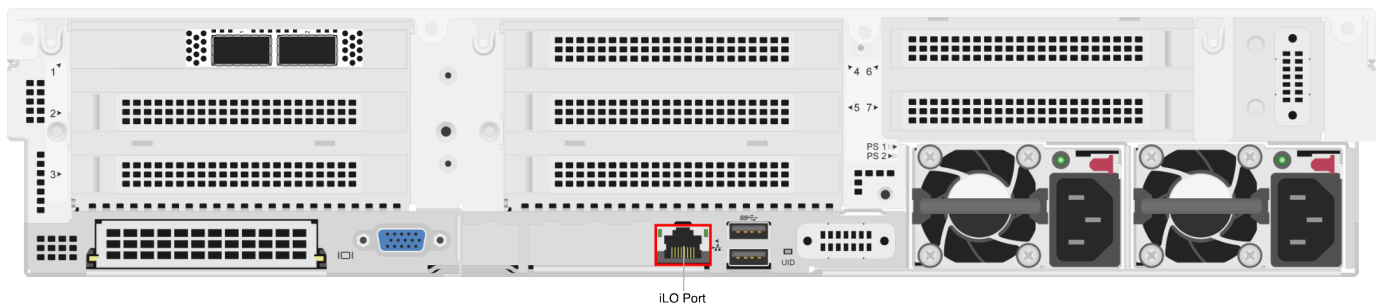

Your nodes receive DHCP address assignments by default. When you configure a node's iLO port, you can access the node by using the IP address (that the DHCP server assigns to the node) and a browser that supports HTML5, Java, or .NET.

⚠ Important

We strongly recommend separating your iLO access network from your client-facing network.

To access iLO configuration from the BIOS System Utilities menu, press F9.

Note

The IMPI username and password are unrelated to your Qumulo administrative credentials.

iLO Configuration

To configure the iLO port, you must use `ipmitool`. For more information, see the following HPE resources:

- [HPE iLO 5 User Guide](#)
- [HPE iLO IPMI User Guide](#)

Replacing Hardware Components in Your HPE Apollo 4200 G10 Plus Nodes

This section explains how to replace hardware components in HPE Apollo 4200 G10 plus nodes.

⚠ Caution

- We strongly recommend engaging an on-site engineer to replace failed hardware components including but not limited to any procedure that:
 - This guide doesn't cover
 - You haven't received training on
 - Requires precautions to avoid damage caused by electrostatic discharge (ESD) by using industry standard anti-static equipment (such as gloves or wrist straps)
- We don't recommend updating firmware on Qumulo-certified hardware nodes unless the equipment manufacturer or a member of the Qumulo Care Team advises you to do so. For questions about this process, [contact the Qumulo Care Team](#).

To Perform the Part Replacement Procedure by Using the FVT

When you replace a component such as the motherboard or a NIC card in your node, you must ensure that the firmware version and configuration are correct for your new components. To do this, you must perform the part replacement procedure by using the FVT.

1. Boot by using the latest version of the Qumulo Core USB Drive Installer.
2. Select **[*] Perform maintenance**.
3. Select **[2] Perform automatic repair after part replacement (non-destructive)**.

The part replacement procedure runs and the **FVT passed!** message appears.

ℹ Note

In some cases, after the part replacement procedure, the message **FIX: Run the FVT flash command.** appears. Enter 1 as you would for a fixable issue to reboot the node and then repeat the part replacement procedure.

Replacing a HDD or SSD Drive

Your HPE Apollo 4200 Gen10 Plus chassis contains either 24 or 9 HDDs and either 8 or 3 SSDs.

For information about replacing an NVMe drive, see [Storage Drives \(HDDs and SSDs\)](#) in the HPE documentation.

Replacing an M.2 Boot Drive

Your HPE Apollo 4200 Gen10 Plus chassis contains one NVMe boot drive on a riser card.

For information about replacing an M.2 boot drive, see [Installing an M.2 Solid State Drive](#) in the HPE documentation.

Initializing the Replacement Boot Drive

After you replace the boot drive, you must initialize the replacement boot drive by using the Qumulo Core Installer and then rebuild the replacement boot drive by using a script on the node in your cluster.

Step 1: Initialize the Replacement Boot Drive

✓ Tip

To get the correct version of the Qumulo Core Installer for the node in your cluster, [contact the Qumulo Care Team](#)

1. [Create a Qumulo Core USB Drive Installer \(page 10\)](#).
2. Power on your node, enter the boot menu, and select your USB drive.

The Qumulo Core Installer begins to run automatically.

3. When prompted, take the following steps:
 - a. Select `[x] Perform maintenance`.
 - b. Select `[1] Boot drive reset` and then follow the prompts.

The Qumulo Core Installer initializes the boot drive.

4. When the process is complete, the node is powered down automatically.

Step 2: Rebuild the Replacement Boot Drive

1. Power on your node and log in to the node by using the `qq` CLI.
2. To get `root` privileges, run the `sudo qsh` command.
3. To stop the Qumulo Networking Services, run the `service qumulo-networking stop` command.
4. To configure the IP address for the node, run the `ip addr add` command and specify the node's IP address. For example:

```
ip addr add 203.0.113.0/CDR dev bond0
```

5. Ensure that the node can ping other nodes in the cluster.
6. Run the `rebuild_boot_drive.py` script and specify the IP address of *another node* in the cluster, the ID of the node whose boot drive has been replaced, and the password of the administrative account of the cluster. For example:

Note

If your password includes special characters such as the parenthesis (()) or the asterisk (*), use the backslash (\) to escape these characters.

```
/opt/qumulo/rebuild_boot_drive.py \  
  --address 203.0.113.1 \  
  --node-id 2 \  
  --username admin \  
  --password my\ (Special\ *Password
```

Follow the prompts.

7. When the process is complete, reboot the node.

Replacing a Power Supply Unit (PSU)

Your HPE Apollo 4200 Gen10 Plus chassis contains two PSUs.

For information about replacing a PSU, see [Power Supply](#) in the HPE documentation.

Replacing a Fan

Your HPE Apollo 4200 Gen10 Plus chassis has five internal fans.

For information about replacing a fan, see [System Fans](#) in the HPE documentation.

Replacing a DIMM

Your HPE Apollo 4200 Gen10 Plus chassis has 24 DIMM slots.

For information about replacing a DIMM, see [DIMM Installation](#) in the HPE documentation.

Note

To identify which DIMM failed, you must use the baseboard management controller (BMC) on the node or another hardware monitoring solution.

HPE ProLiant DL325 Gen10 Plus

Wiring Nodes and Networking Your HPE ProLiant DL325 Gen10 Plus Cluster

This section explains how to wire NIC ports on HPE ProLiant DL325 Gen10 Plus nodes and how to network a cluster.

This platform uses a *split networking configuration* in which different NICs handle back-end and front-end traffic. You can connect the front-end and back-end NICs to the same switch or to different switches.

✓ Tip

To identify the eth port, run the following command:

```
for i in /sys/class/net/eth*; \  
do echo $i; \  
cat $i/device/uevent | \  
grep -i pci_slot; \  
done
```

Node NICs and Ports

The following diagram shows the NICs and ports on HPE ProLiant DL325 Gen10 Plus nodes. On this platform, there are two sets of NICs, one for the front end and one for the back end.

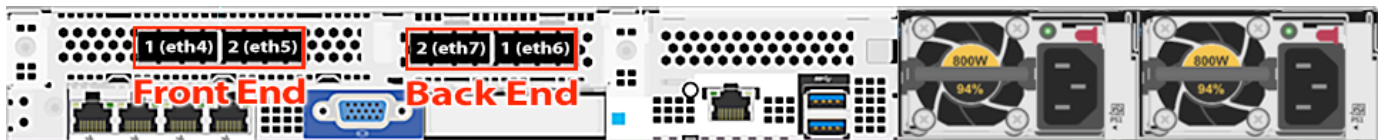

Prerequisites

- A network switch with the following criteria:
 - 100 Gbps Ethernet connection
 - Fully non-blocking architecture
 - IPv6 compatibility
- Compatible network cables
- A sufficient number of ports for connecting all nodes to the same switch fabric

- One static IP for each node, for each defined VLAN

⚠ Important

Before you connect any Qumulo-supported equipment to your network, we strongly recommend consulting with your network engineering team.

Recommended Configuration

- One set of redundant switches for the front-end network, with an MTU that matches that of the clients that use the storage cluster. Typically, we recommend 1,500 MTU but in some instances 9,000 MTU is the optimal setting.
- One set of redundant switches for the back-end network (9,000 MTU minimum)
- One physical connection to each redundant switch, for each node
- One Link Aggregation Control Protocol (LACP) port-channel for each network (front-end and back-end) on each node with the following configuration:
 - Active mode
 - Slow transmit rate
 - Trunk port with a native VLAN
- DNS servers
- Network Time Protocol (NTP) server
- Firewall protocol or ports configured for [Qumulo Care Proactive Monitoring](#)
- Where **N** is the number of nodes, up to 10 **N-1** floating IP addresses for each node, for each client-facing VLAN
- Nodes connected at their maximum Ethernet speed (this ensures advertised performance). To avoid network bottlenecks, Qumulo validates system performance with this configuration by using clients connected at the same link speed and to the same switch as the nodes.

Connecting to Redundant Switches

This section explains how to connect a four-node cluster to dual switches for redundancy. We recommend this configuration. If either switch becomes inoperative, the cluster remains accessible through the remaining switch.

- **Front End**
 - Connect the two front-end 100 Gbps ports on your nodes to separate switches.
 - The uplinks to the client network must equal the bandwidth from the cluster to

the switch.

- The two ports form an LACP port channel by using a multi-chassis link aggregation group.
- **Back End**
 - Connect the two back-end 100 Gbps NIC ports on your nodes to separate switches.
 - Use an appropriate inter-switch link or virtual port channel.
- **MTU**
 - For all connection speeds, the default behavior is that of an LACP with 1,500 MTU for the front-end and 9,000 MTU for the back-end.

Connecting to a Single Switch

This section explains how to connect a four-node cluster to a single switch.

- **Front End**
 - Each node has two front-end 100 Gbps NIC ports connected to a single switch.
 - The uplinks to the client network must equal the bandwidth from the cluster to the switch.
 - The two ports form an LACP port channel.
- **Back End**
 - Each node has two back-end 100 Gbps ports connected to a single switch.
- **MTU**
 - For all connection speeds, the default behavior is that of an LACP with 1,500 MTU for the front-end and 9,000 MTU for the back-end.

Four-Node Cluster Architecture Diagrams

The following is the recommended configuration for a four-node cluster connected to an out-of-band management switch, redundant front-end switches, and redundant back-end switches.

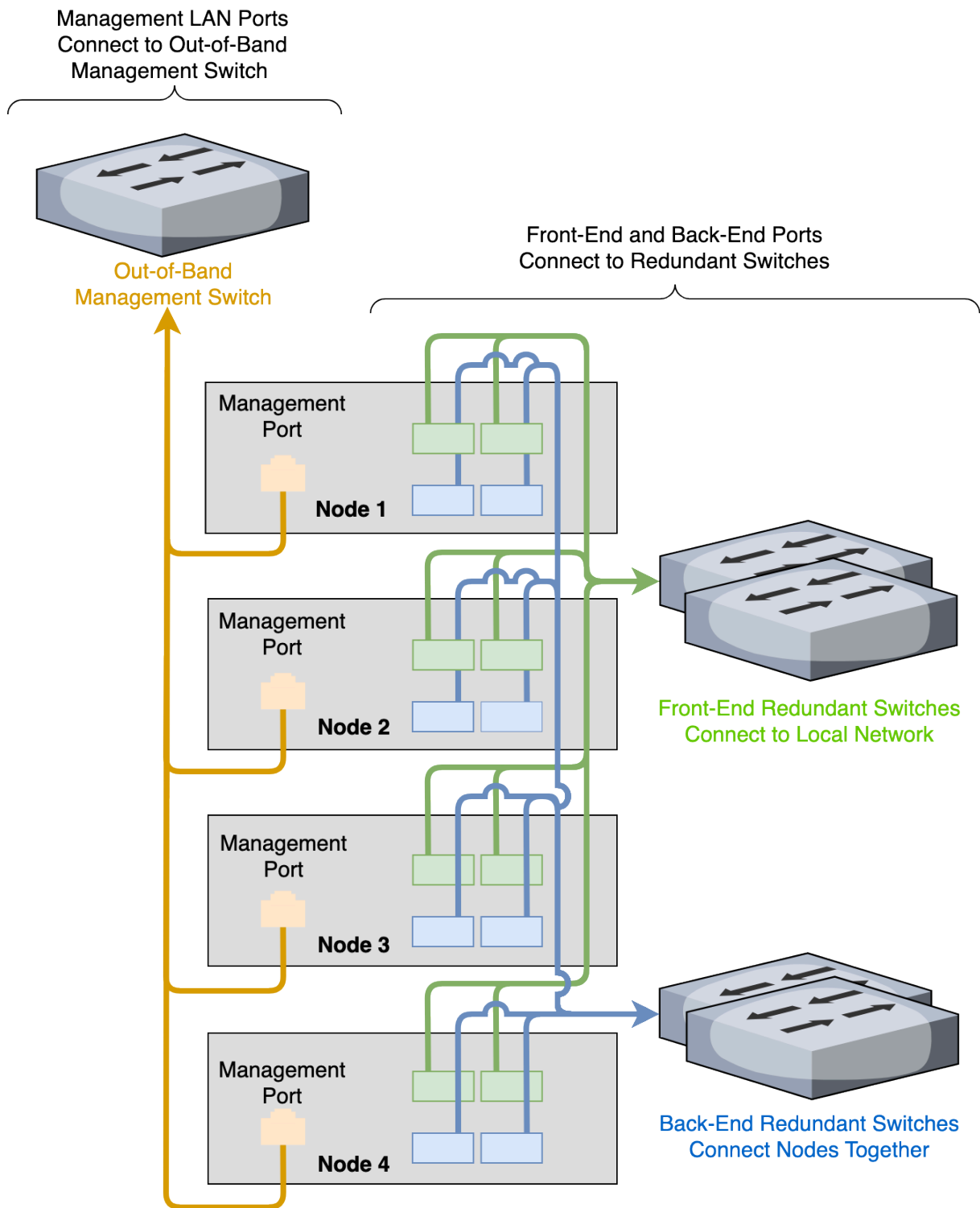

⚠ Important

For your node to work correctly, you must connect at least one port in each NIC.

Creating and Configuring a Qumulo Cluster with HPE ProLiant DL325 Gen10 Plus Nodes

This section explains how to prepare HPE ProLiant DL325 Gen10 Plus nodes for creating a Qumulo cluster. This guide is for system administrators, professional service providers, and colleagues in your organization who are responsible for installing and configuring server hardware.

Prerequisites

[Qumulo Core USB Drive Installer](#)

Step 1: Verify Your Node

1. Shut down your node and connect a display, a keyboard, and a mouse to it.
2. Plug the [Qumulo Core USB Drive Installer](#) into an available USB port on the node and then press the power button.

Step 2: Boot by Using the Qumulo Core USB Drive Installer

1. On the HPE ProLiant boot screen, press F11.

Note

The [Boot Menu](#) page might take a few minutes to appear.

2. On the [Boot Menu](#) page, to perform a one-time boot, do one of the following:
 - If the [Legacy BIOS One-Time Boot Menu](#) option is available, click it.
 - If the [Legacy BIOS One-Time Boot Menu](#) option is unavailable, click [Generic USB Boot](#) and continue to run the Field Verification Tool (FVT).
3. In the [Question](#) dialog box, click [OK](#).

Note

The [Default Boot Override Options](#) page might take a few minutes to appear.

4. In the [Default Boot Override Options](#) menu, select [2\) One Time Boot to USB DriveKey](#).

Step 3: Run the Field Verification Tool (FVT)

After the node reboots, the Qumulo Installer runs automatically.

1. Choose [\[1\] Factory reset \(DESTROYS ALL DATA\)](#).

2. To perform a clean installation of Qumulo Core on your node, type **DESTROY ALL DATA** (case-sensitive).
3. Review the verification results and consider the following before proceeding with the installation.
 - If the **FVT Passed!** message appears, select **[1] Install Qumulo Core**.
 - If **FAIL** messages appear, use one of the following resolutions.
4. When the FVT passes all checks, select **[1] Install Qumulo Core**.

Fixable Issues During Installation

If the FVT finds fixable issues, it prompts you to auto-correct any detected issues, depending on your installation scenario. Issues that the FVT can auto-correct include the following:

- BIOS Configuration
- Drive firmware
- NVMe sector size
- NIC mode
- NIC firmware
- Boot order

1. To attempt auto-correction, select **[1] Run FVT Flash**. This will try to fix issues then reboot. If the fixes are successful, the FVT reboots the node automatically.
2. To re-attempt verification, [boot by using the Qumulo Core USB Drive Installer \(page 132\)](#) and then continue the installation.

Non-Fixable Issues

If the FVT is unable to auto-correct any issues, the message **Not fixable issues were detected** appears, providing reasons for failure.

For help with troubleshooting your node, [contact the Qumulo Care Team](#).

Step 4: Create and Configure Your Cluster

1. Review the **End User Agreement**, click **I agree to the End User Agreement**, and then click **Submit**.
2. Name your cluster.
3. On the **1. Set up cluster** page, select the nodes to add to your cluster.

As you select nodes, the installer updates the total capacity of your cluster at the bottom of the page.

Note

If any nodes are missing, confirm that they are powered on and connected to the same network.

4. Confirm that the individual nodes have the expected capacity.
5. On the **2. Confirm cluster protection level** page, Qumulo Core selects the recommended 2, 3, or 4-drive protection level based on your cluster size and node type.
6. If the **Customize Protection Level** option appears, you can increase your system resilience by selecting 3- or 4-drive protection.

Important

- Qumulo Core 6.1.0.1 and 6.1.1 support Adaptive Data Protection by letting you reconfigure your cluster's fault tolerance level and storage efficiency only when you add nodes to your cluster.

Depending on your cluster, Qumulo Core shows configuration options that offer better fault tolerance levels, better storage efficiency, or both benefits. To enable Adaptive Data Protection for your cluster, you must [contact the Qumulo Care Team](#).

- In Qumulo Core 6.1.2 (and higher), you can change your cluster's data protection configuration when you add or replace nodes by using the `qq` CLI.
- Using 3- or 4-drive protection reduces the total capacity of your cluster.

7. Enter a password for the administrative account and click **Create Cluster**.
8. To access the Qumulo Core Web UI, connect to any node by entering its IP address into a browser.

Front and Rear Drive Bays on HPE ProLiant DL325 Gen10 Plus Nodes

This section explains the front and rear drive bays in HPE ProLiant DL325 Gen10 Plus nodes. On this platform, the drives in a node are arranged into *rows* and groups called *boxes*.

Front Drive Row

The following diagram shows the front drive row. In the diagram, box 1 holds bays 1-8 (indicated in green) and box 2 holds bays 1-2 (indicated in orange).



Second Drive Row

The second drive row flips up behind the front drive row in the node.



For the second row, box 3 holds bays 1-8 and box 4 holds bays 1-2.



Boot Drive

The boot drive is in box 1, bay 1.

⚠ Important

Before you remove the boot drive [contact the Qumulo Care Team](#) for additional instructions.

Configuring Integrated Lights Out (iLO) on HPE ProLiant DL325 Gen10 Plus Nodes

This section explains how to configure Integrated Lights Out (iLO) on HPE ProLiant DL325 Gen10 Plus nodes.

Prerequisites

To configure the iLO port, you must have root access to the client-facing network through SSH. For example, you can run the `sudo -s` command.

⚠ Important

Access to the iLO port on a public LAN can have serious security implications because it can grant anyone with credentials direct access to your server's hardware and console. Follow security best practices when implementing iLO access.

How the iLO Port Works

Your node provides iLO support for out-of-band maintenance access even when the node is plugged in but powered off. The following diagram shows the location of the iLO port.

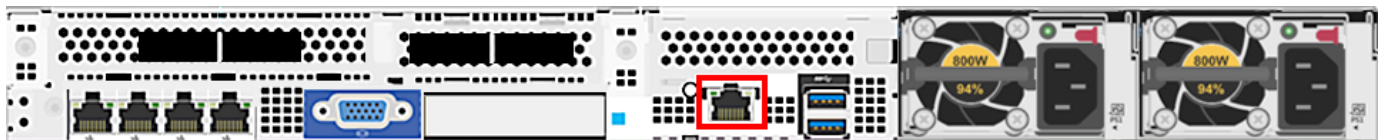

Your nodes receive DHCP address assignments by default. When you configure a node's iLO port, you can access the node by using the IP address (that the DHCP server assigns to the node) and a browser that supports HTML5, Java, or .NET.

⚠ Important

We strongly recommend separating your iLO access network from your client-facing network.

To access iLO configuration from the BIOS System Utilities menu, press F9.

📘 Note

The IMPI username and password are unrelated to your Qumulo administrative credentials.

iLO Configuration

To configure the iLO port, you must use `ipmitool`. For more information, see the following HPE resources:

- [HPE iLO 5 User Guide](#)
- [HPE iLO IPMI User Guide](#)

Replacing Hardware Components in Your HPE DL325 Gen10 Plus

This section explains how to replace hardware components in HPE DL325 Gen10 Plus nodes.

⚠ Caution

- We strongly recommend engaging an on-site engineer to replace failed hardware components including but not limited to any procedure that:
 - This guide doesn't cover
 - You haven't received training on
 - Requires precautions to avoid damage caused by electrostatic discharge (ESD) by using industry standard anti-static equipment (such as gloves or wrist straps)
- We don't recommend updating firmware on Qumulo-certified hardware nodes unless the equipment manufacturer or a member of the Qumulo Care Team advises you to do so. For questions about this process, [contact the Qumulo Care Team](#).

To Perform the Part Replacement Procedure by Using the FVT

When you replace a component such as the motherboard or a NIC card in your node, you must ensure that the firmware version and configuration are correct for your new components. To do this, you must perform the part replacement procedure by using the FVT.

1. Boot by using the latest version of the Qumulo Core USB Drive Installer.
2. Select **[*] Perform maintenance**.
3. Select **[2] Perform automatic repair after part replacement (non-destructive)**.

The part replacement procedure runs and the **FVT passed!** message appears.

📘 Note

In some cases, after the part replacement procedure, the message **FIX: Run the FVT flash command.** appears. Enter 1 as you would for a fixable issue to reboot the node and then repeat the part replacement procedure.

Replacing an NVMe Drive

Your HPE ProLiant DL325 Gen10 Plus chassis contains either 19 or 9 NVMe drives.

For information about replacing an NVMe drive, see [Storage Drives \(NVMe\)](#) in the HPE documentation.

Replacing an M.2 Boot Drive

Your HPE ProLiant DL325 Gen10 Plus chassis contains one M.2 boot drive on a riser card.

For information about replacing a boot drive, see [Removing and Replacing the Boot Device](#) in the HPE documentation.

Initializing the Replacement Boot Drive

After you replace the boot drive, you must initialize the replacement boot drive by using the Qumulo Core Installer and then rebuild the replacement boot drive by using a script on the node in your cluster.

Step 1: Initialize the Replacement Boot Drive

✓ Tip

To get the correct version of the Qumulo Core Installer for the node in your cluster, [contact the Qumulo Care Team](#)

1. [Create a Qumulo Core USB Drive Installer \(page 10\)](#).
2. Power on your node, enter the boot menu, and select your USB drive.

The Qumulo Core Installer begins to run automatically.

3. When prompted, take the following steps:
 - a. Select `[x] Perform maintenance`.
 - b. Select `[1] Boot drive reset` and then follow the prompts.

The Qumulo Core Installer initializes the boot drive.

4. When the process is complete, the node is powered down automatically.

Step 2: Rebuild the Replacement Boot Drive

1. Power on your node and log in to the node by using the `qq` CLI.
2. To get `root` privileges, run the `sudo qsh` command.
3. To stop the Qumulo Networking Services, run the `service qumulo-networking stop` command.
4. To configure the IP address for the node, run the `ip addr add` command and specify the node's IP address. For example:

```
ip addr add 203.0.113.0/CDR dev bond0
```

5. Ensure that the node can ping other nodes in the cluster.
6. Run the `rebuild_boot_drive.py` script and specify the IP address of *another node* in the cluster, the ID of the node whose boot drive has been replaced, and the password of the administrative account of the cluster. For example:

Note

If your password includes special characters such as the parenthesis (()) or the asterisk (*), use the backslash (\) to escape these characters.

```
/opt/qumulo/rebuild_boot_drive.py \  
  --address 203.0.113.1 \  
  --node-id 2 \  
  --username admin \  
  --password my\ (Special\ *Password
```

Follow the prompts.

7. When the process is complete, reboot the node.

Replacing a Power Supply Unit (PSU)

Your HPE ProLiant DL325 Gen10 Plus chassis contains two PSUs.

For information about replacing a PSU, see [Power Supply](#) in the HPE documentation.

Replacing a Fan

Your HPE ProLiant DL325 Gen10 Plus chassis has eight internal fans.

For information about replacing a fan, see [System Fans](#) in the HPE documentation.

Replacing a DIMM

Your HPE ProLiant DL325 Gen10 Plus chassis has 8 DIMM slots.

For information about replacing a DIMM, see [DIMM Installation](#) in the HPE documentation.

Note

To identify which DIMM failed, you must use the baseboard management controller (BMC) on the node or another hardware monitoring solution.

Quiver 1U All-NVMe Gen1

Racking Your Quiver 1U All-NVMe Gen1 Nodes

This section explains how to rack Quiver 1UA Gen1 nodes in a data center.

Inserting the Chassis into the Server Rack

⚠ Important

- We strongly recommend using a server lift or that two people perform this task.
- If you install the Quiver 1UA Gen1 [245 TB \(page 0\)](#) node type, ensure that the node cabling has sufficient slack to allow you to reach the [internal storage bays \(page 147\)](#).

To Insert a Chassis without Drives into a Standard Server Rack

For nodes without drives, follow the [Tool-Less Friction Rail Kit Installation Guide \(page 0\)](#) in the ASUS documentation.

To Insert a Chassis with Internal Drives into a Deep Server Rack

For nodes with drives in [internal storage bays \(page 147\)](#), you can purchase the optional [1.2m Half Extension Ball Bearing Type Rail Kit \(page 0\)](#) together with the [Cable Management Arm !\[\]\(6458ec146e3b506e3ed571bda3a1e7cb_img.jpg\)](#). These two items replace the Tool-Less Friction Rail Kit.

i Note

To permit access to the internal storage bays, leave clearance at the top of the chassis.

Removing the Chassis from the Server Rack

Perform the steps for inserting the chassis in reverse order.

Configuring the Intelligent Platform Management Interface (IPMI) and Wiring Your Quiver 1U All-NVMe Gen1 Nodes

This section explains how to wire the out-of-band management (IPMI) port, 100 Gbps ports, and power on Quiver 1UA Gen1 nodes.

Depending on its [technical specifications \(page 0\)](#), your node uses *unified* or *split networking configuration*. For more information, see [Connecting the 100 Gbps Ports \(page 144\)](#).

Note

- For dual-NIC nodes, the left NIC is for the front end and the right NIC is for the back end.
- The two rightmost Ethernet ports on the back of your node are unused.

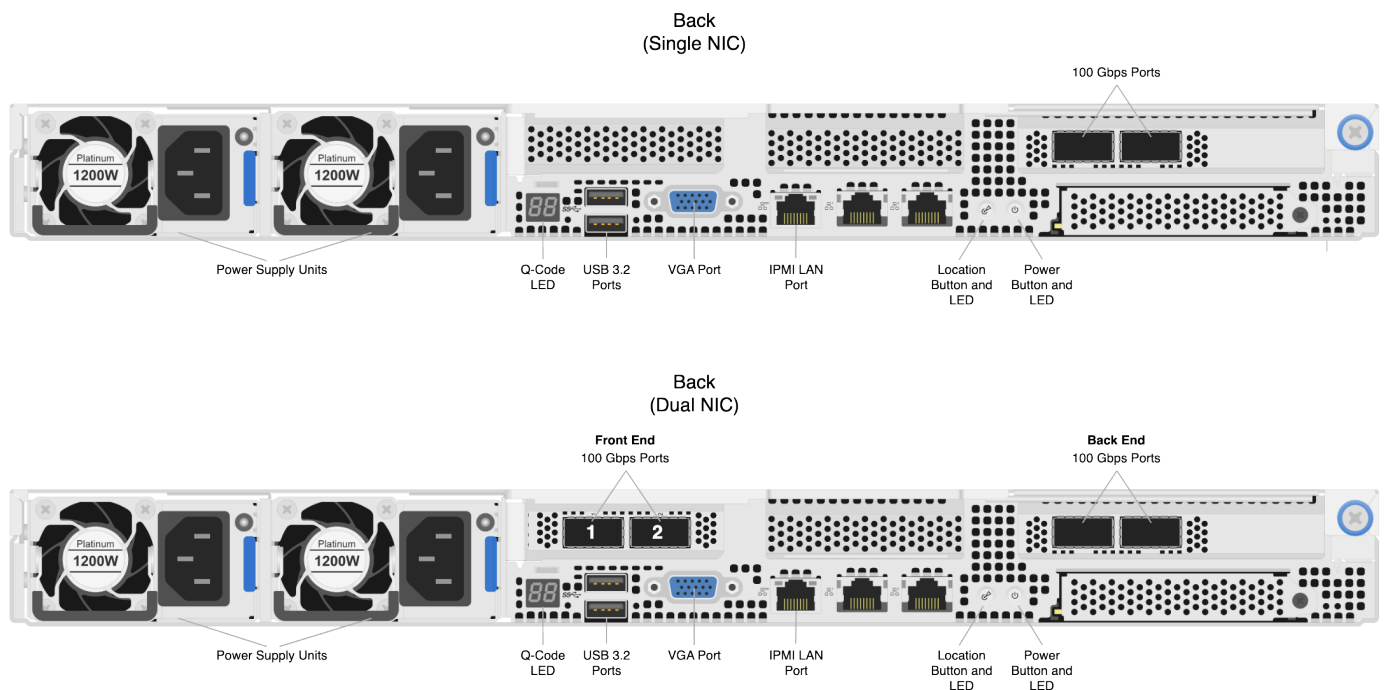

How the IPMI Port Works

The dedicated out-of-band management port allows functionality such as remote display, control, and power. The port uses the Intelligent Platform Management Interface (IPMI) protocol.

The IPMI port is located on the back of your node. For more information, see the documentation from your hardware vendor.

For more information, see [Default IPMI Usernames and Passwords](#)  on Qumulo Care.

Note

The IPMI username and password are unrelated to your Qumulo administrative credentials.

To configure the IPMI port, you must use the Server Management Interface. For more information, see [ASMB11-iKVM Server Management Board User Guide \(page 0\)](#) in the ASUS documentation.

Step 2: Connecting the 100 Gbps Ports

After you connect the IPMI port, connect your 100 Gbps ports (compatible with QSFP28 or QSFP56).

- **Single NIC:** This platform uses a *unified networking configuration* in which the same NIC handles back-end and front-end traffic. In this configuration, each networking port provides communication with clients and between nodes. You can connect the NIC's ports to the same switch or to different switches.
- **Dual NIC:** This platform uses a *split networking configuration* in which different NICs handle back-end and front-end traffic. You can connect the front-end and back-end NICs to the same switch or to different switches.

Tip

To identify the eth port, run the following command:

```
for i in /sys/class/net/eth*; \  
do echo $i; \  
cat $i/device/uevent | \  
grep -i pci_slot; \  
done
```

Step 3: Connecting the Power

After you connect your 100 Gbps ports, connect power to the node. There are two power sockets on the back of your node. To maximize redundancy, connect each PSU to a separate power supply or power distribution unit (PDU).

Creating and Configuring a Qumulo Cluster with Quiver 1U All-NVMe Gen1 Nodes

This section explains how to prepare Quiver 1UA Gen1 nodes for creating a Qumulo cluster.

Step 1: Verify Your Node

1. Shut down your node and connect a display, a keyboard, and a mouse to it.
2. Plug the [Qumulo Core USB Drive Installer](#) into an available USB port on the node and then press the power button.

Step 2: Boot by Using the Qumulo Core USB Drive Installer

1. When the node powers on and begins to boot, on the ASUS screen, press F8.

Note

- The boot setting is persistent: When you boot from a USB drive once, the node continues to boot from the USB drive. After you finish installing Qumulo Core, remove the USB drive from the node.
- Depending on your node configuration, it might take longer than usual to boot up for the first time.

2. On the **Please select boot device:** screen, select your USB drive (usually labeled with **UEFI OS**) and boot into it.

The Qumulo Core installation begins.

Step 3: Create and Configure Your Cluster

Important

The dual-NIC variant of your Quiver 1UA Gen1 node uses a split networking configuration. Ensure that the [front-end and back-end networks \(page 144\)](#) are connected and operational before creating your cluster. If only one of the networks is connected and operational during the cluster creation process, Qumulo Core deploys with the unified networking configuration.

1. Review the **End User Agreement**, click **I agree to the End User Agreement**, and then click **Submit**.
2. Name your cluster.

3. On the **1. Set up cluster** page, select the nodes to add to your cluster.

As you select nodes, the installer updates the total capacity of your cluster at the bottom of the page.

Note

If any nodes are missing, confirm that they are powered on and connected to the same network.

4. Confirm that the individual nodes have the expected capacity.
5. On the **2. Confirm cluster protection level** page, Qumulo Core selects the recommended 2, 3, or 4-drive protection level based on your cluster size and node type.
6. If the **Customize Protection Level** option appears, you can increase your system resilience by selecting 3- or 4-drive protection.

Important

- Qumulo Core 6.1.0.1 and 6.1.1 support Adaptive Data Protection by letting you reconfigure your cluster's fault tolerance level and storage efficiency only when you add nodes to your cluster.

Depending on your cluster, Qumulo Core shows configuration options that offer better fault tolerance levels, better storage efficiency, or both benefits. To enable Adaptive Data Protection for your cluster, you must [contact the Qumulo Care Team](#).

- In Qumulo Core 6.1.2 (and higher), you can change your cluster's data protection configuration when you add or replace nodes by using the `qq` CLI.
- Using 3- or 4-drive protection reduces the total capacity of your cluster.

7. Enter a password for the administrative account and click **Create Cluster**.
8. To access the Qumulo Core Web UI, connect to any node by entering its IP address into a browser.

Drive Bay Mapping in Quiver 1U All-NVMe Gen1 Nodes

This section explains the drive bay mapping in Quiver 1UA Gen1 nodes.

Your Quiver 1UA Gen1 chassis contains up to 12 2.5" hot-swap NVMe drives in front storage bays and one boot drive in an internal M.2 expansion slot. The following is the mapping for the drives.

Note

Certain node types have four additional NVMe drives in internal storage bays. For more information, see [Technical Specifications \(page 0\)](#).

NVMe Drives in Front Storage Bays

There are 12 2.5" hot-swap NVMe drives attached with four screws to trays in front storage bays. For more information, see [Installing a 2.5-Inch Storage Device to a Front Storage Bay \(page 0\)](#) in the ASUS documentation.

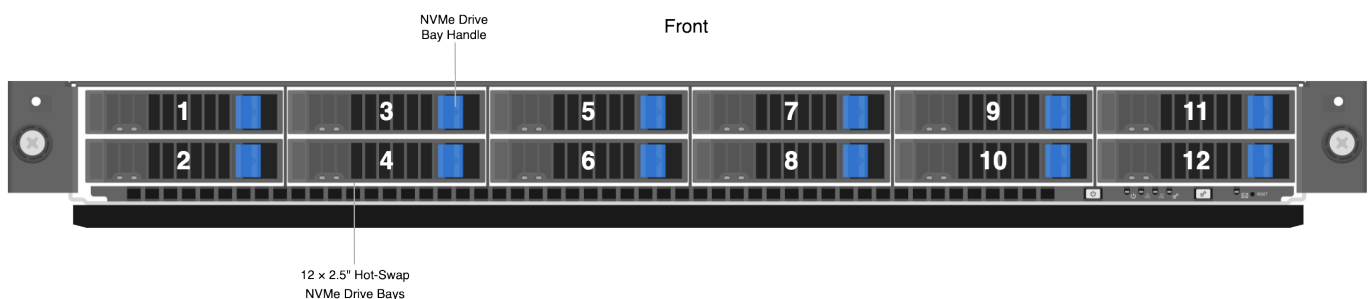

NVMe Drives in Internal Storage Bays

There are 4 2.5" hot-swap NVMe drives in snap-in, toolless trays in internal storage bays. For more information, see [Installing a 2.5-Inch Storage Device to an Internal Storage Bay \(page 0\)](#) in the ASUS documentation.

Caution

To access the internal storage bays, you must slide the chassis out of its rack. While pulled out of the rack, the chassis must have support.



NVMe M.2 Boot Drive

The boot drive is located at the M.2 expansion slot at connector NGFF1. For more information, see [Installing M.2 \(NGFF\) Cards \(page 0\)](#) in the ASUS documentation.

Panel LEDs on Quiver 1U All-NVMe Gen1 Nodes

This section explains the LEDs on Quiver 1UA Gen1 nodes.

Front Panel LEDs and Buttons

On the front, right side of your node, there are four LEDs.

Note

The LAN1 and LAN2 LEDs are unused.

Label	Color and Behavior	Description
Power LED	● (solid green)	The node is powered on
Message LED	Off	The node is functioning normally
Message LED	● (solid amber)	A hardware event has occurred
Location LED	Off	The node is functioning normally
Location LED	● (solid blue)	The location button has been pressed

Front and Internal Storage Bay NVMe Drive Carrier LEDs

Each NVMe drive carrier in front and internal storage bays has a red LED at the top and a green LED at the bottom



Note

When both LEDs are off, the storage device isn't present

Location	Color and Behavior	Description
Top	● (solid red)	Storage device failed
Top	Off	Storage device healthy
Bottom	● (solid green)	Storage device is powered on
Bottom	● (blinking green)	Reading data from, or writing data to the storage device

Rear Panel LEDs and Buttons

On the back of your node, there are three LEDs.

Label	Color and Behavior	Description
Q-Code LED	 (solid amber)	Indicates a post code for troubleshooting. For more information, see the Q-Code Table (page 0) in the ASUS documentation.
Location Button LED	 (solid blue)	The location button has been pressed. To turn off the LED, press the location button again.
Power LED	 (solid green)	The node is powered on.

Networking Your Quiver 1U All-NVMe Gen1 Cluster

This section explains how to network a Quiver 1U All-NVMe Gen1 cluster.

✓ Tip

To identify the eth port, run the following command:

```
for i in /sys/class/net/eth*; \
do echo $i; \
cat $i/device/uevent | \
grep -i pci_slot; \
done
```

Prerequisites

📘 Note

Before you create your Qumulo cluster, if your client environment requires Jumbo Frames (9,000 MTU), configure your switch to support a higher MTU.

Your node requires the following resources.

- A network switch with the following specifications:
 - 100 Gbps Ethernet
 - Fully non-blocking architecture
 - IPv6 capability
- Compatible networking cables
- A sufficient number of ports for connecting all nodes to the same switch fabric
- One static IP for each node, for each defined VLAN

Recommended Configuration

- **Single NIC:** This platform uses a *unified networking configuration* in which the same NIC handles back-end and front-end traffic. In this configuration, each networking port provides communication with clients and between nodes. You can connect the NIC's ports to the same switch or to different switches. However, for greater reliability, we recommend connecting both 100 Gbps ports on every node to each switch.

- **Dual NIC:** This platform uses a *split networking configuration* in which different NICs handle back-end and front-end traffic. You can connect the front-end and back-end NICs to the same switch or to different switches. However, for greater reliability, we recommend connecting all four 100 Gbps ports on every node: Connect both front-end NIC ports to the front-end switch and both back-end NIC ports to the back-end switch.

⚠ Important

- Never network single-NIC and dual-NIC nodes within the same cluster.
- Never configure a dual-NIC platform with a unified networking configuration.
- We don't recommend connecting to a single back-end NIC port because the node becomes unavailable if the single connection fails.

We recommend the following configuration for your node.

- Your Qumulo MTU configured to match your client environment
- Physical connections
 - **Single NIC:** Two physical connections for each node, one connection for each redundant switch
 - **Dual NIC:** One physical connection for each node, for each redundant switch
- One Link Aggregation Control Protocol (LACP) port-channel for each network on each node, with the following configuration
 - Active mode
 - Slow transmit rate
 - Access port or trunk port with a native VLAN
- DNS servers
- A Network Time Protocol (NTP) server
- Firewall protocols or ports allowed for proactive monitoring
- Where **N** is the number of nodes, **N-1** floating IP addresses for each node, for each client-facing VLAN

Connecting to Redundant Switches

For redundancy, we recommend connecting your cluster to dual switches. If either switch becomes inoperative, the cluster is still be accessible from the remaining switch.

Single NIC

- Connect the two NIC ports (2 × 100 Gbps) on your nodes to separate switches.
- The uplinks to the client network must equal the bandwidth from the cluster to the switch.
- The two ports form an LACP port channel by using a multi-chassis link aggregation group.
- Use an appropriate inter-switch link or virtual port channel.

Dual NIC

- **Front End**
 - Connect the two front-end NIC ports (2 × 100 Gbps) on your nodes to separate switches.
 - The uplinks to the client network must equal the bandwidth from the cluster to the switch.
 - The two ports form an LACP port channel by using a multi-chassis link aggregation group.
- **Back End**
 - Connect the two back-end NIC ports (2 × 100 Gbps) on your nodes to separate switches.
 - Use an appropriate inter-switch link or virtual port channel.
- **Link Aggregation Control Protocol (LACP)**
 - For all connection speeds, the default behavior is that of an LACP with 1,500 MTU for the front-end and 9,000 MTU for the back-end interfaces.

Connecting to a Single Switch

You can connect a your cluster to a single switch. If this switch becomes inoperative, the entire cluster becomes inaccessible.

Single NIC

- Connect the two NIC ports (2 × 100 Gbps) on your nodes to a single switch.
- The uplinks to the client network must equal the bandwidth from the cluster to the switch.
- The two ports form an LACP port channel.

Dual NIC

- **Front End**

- Connect the two front-end NIC ports (2 × 100 Gbps) to a single switch.
- The uplinks to the client network must equal the bandwidth from the cluster to the switch.
- The two ports form an LACP port channel.
- **Back End**
 - Connect the two band-end ports (2 × 100 Gbps) to a single switch.
 - Link Aggregation Control Protocol (LACP)
 - For all connection speeds, the default behavior is that of an LACP with 1,500 MTU for the front-end and 9,000 MTU for the back-end interfaces.

⚠ Important

The dual-NIC variant of your Quiver 1UA Gen1 node uses a split networking configuration. Ensure that the [front-end and back-end networks \(page 144\)](#) are connected and operational before creating your cluster. If only one of the networks is connected and operational during the cluster creation process, Qumulo Core deploys with the unified networking configuration.

Four-Node Cluster Architecture Diagrams

Single NIC

The following is the recommended configuration for a four-node cluster connected to an out-of-band management switch and redundant switches.

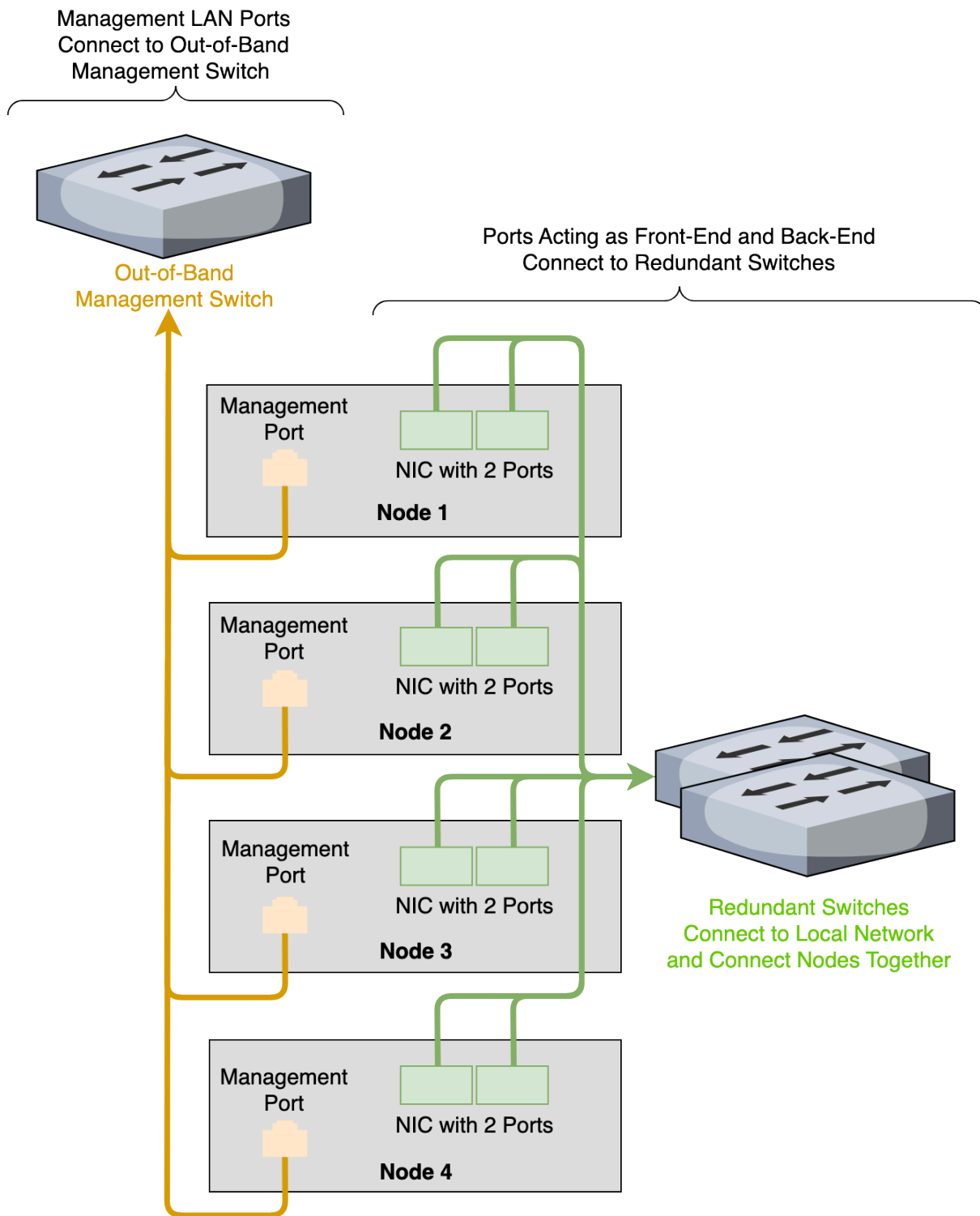

Dual NIC

The following is the recommended configuration for a four-node cluster connected to an out-of-band management switch, redundant front-end switches, and redundant back-end switches.

Management LAN Ports
Connect to Out-of-Band
Management Switch

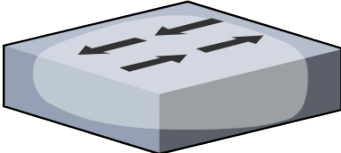

Out-of-Band
Management Switch

Front-End and Back-End Ports
Connect to Redundant Switches

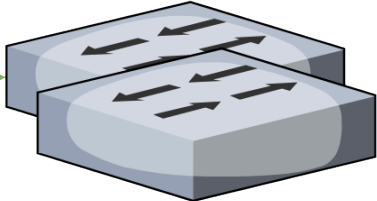
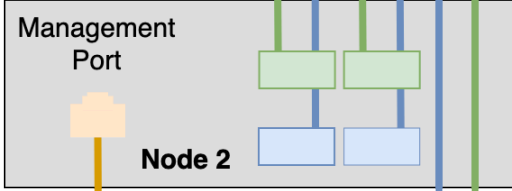

Front-End Redundant Switches
Connect to Local Network

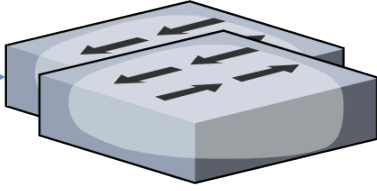

Back-End Redundant Switches
Connect Nodes Together

Replacing Hardware Components in Your Quiver 1U All-NVMe Gen1 Nodes

This section explains how to replace hardware components in Quiver 1U All-NVMe Gen1 nodes.

To Remove and Replace the Top Cover

Follow the instructions in the ASUS documentation:

1. [Remove the rear cover \(page 0\)](#).
2. [Remove the backplane cover \(page 0\)](#).
3. [Remove the air ducts \(page 0\)](#).
4. When reassembling the chassis, follow these instructions in reverse order.

Replacing a NIC

Note

Certain node types have two NICs. For more information, see [Technical Specifications \(page 0\)](#).

Follow the instructions in the ASUS documentation:

- For the left NIC, see [Installing an Expansion Card to the Butterfly Riser Card Bracket \(page 0\)](#).
- For the right NIC, see [Installing an Expansion Card to the Riser Card Bracket \(page 0\)](#).

Initializing the Replacement Boot Drive

After you replace the boot drive, you must initialize the replacement boot drive by using the Qumulo Core Installer and then rebuild the replacement boot drive by using a script on the node in your cluster.

Step 1: Initialize the Replacement Boot Drive

Tip

To get the correct version of the Qumulo Core Installer for the node in your cluster, [contact the Qumulo Care Team](#)

1. [Create a Qumulo Core USB Drive Installer \(page 10\)](#).
2. Power on your node, enter the boot menu, and select your USB drive.

The Qumulo Core Installer begins to run automatically.

3. When prompted, take the following steps:
 - a. Select `[x] Perform maintenance`.
 - b. Select `[1] Boot drive reset` and then follow the prompts.

The Qumulo Core Installer initializes the boot drive.

4. When the process is complete, the node is powered down automatically.

Step 2: Rebuild the Replacement Boot Drive

1. Power on your node and log in to the node by using the `qq` CLI.
2. To get `root` privileges, run the `sudo qsh` command.
3. To stop the Qumulo Networking Services, run the `service qumulo-networking stop` command.
4. To configure the IP address for the node, run the `ip addr add` command and specify the node's IP address. For example:

```
ip addr add 203.0.113.0/CDR dev bond0
```

5. Ensure that the node can ping other nodes in the cluster.
6. Run the `rebuild_boot_drive.py` script and specify the IP address of *another node* in the cluster, the ID of the node whose boot drive has been replaced, and the password of the administrative account of the cluster. For example:

i Note

If your password includes special characters such as the parenthesis (`()`) or the asterisk (`*`), use the backslash (`\`) to escape these characters.

```
/opt/qumulo/rebuild_boot_drive.py \  
--address 203.0.113.1 \  
--node-id 2 \  
--username admin \  
--password my\ (Special\ *Password
```

Follow the prompts.

7. When the process is complete, reboot the node.

Replacing an NVMe Drive in a Front Storage Bay

There are 12 2.5" hot-swap NVMe drives attached with four screws to trays in front storage bays. For more information, see [Installing a 2.5-Inch Storage Device to a Front Storage Bay \(page 0\)](#) in the ASUS documentation.

Replacing an NVMe Drive in an Internal Storage Bay

There are 4 2.5" hot-swap NVMe drives in snap-in, toolless trays in internal storage bays. For more information, see [Installing a 2.5-Inch Storage Device to an Internal Storage Bay \(page 0\)](#) in the ASUS documentation.

Replacing a Power Supply Unit (PSU)

Your Quiver 1UA Gen1 chassis contains two PSUs. Follow the instructions to [replace a power supply module \(page 0\)](#) in the ASUS documentation.

To Replace a System Fan

Your Quiver 1UA Gen1 chassis has five system fans on the left and two on the right. The fans mount to the chassis with a toolless system. For more information, see [Internal Features \(page 0\)](#) in the ASUS documentation.

1. Disconnect a fan from the motherboard. For more information, see [Cable Connections \(page 0\)](#) and [System Fan Connectors \(page 0\)](#) in the ASUS documentation.
2. To remove a fan, lift it upwards from the chassis.

Replacing a DIMM

Your Quiver 1UA Gen1 chassis has 24 DDR5 DIMM slots. For more information, see [System Memory \(page 0\)](#) and [Memory Configurations \(page 0\)](#) in the ASUS documentation.

Follow the instructions for [removing and installing a DIMM \(page 0\)](#) in the ASUS documentation.

Replacing the Node Chassis

Important

After you perform a chassis swap, you must reconfigure the IPMI settings for your node.

Step 1: Remove the Existing Components

1. At the back of the node, disconnect the power cabling from both power supply units (PSUs) and [remove both existing PSUs \(page 159\)](#) from the node.
2. Disconnect the network cabling from the NIC ports and [remove the existing NICs \(page 157\)](#) from the node.

3. Remove the [NVMe drives in front storage bays \(page 159\)](#), the [NVMe drives in internal storage bays \(page 159\)](#) and the NVMe M.2 boot drive from the node.
4. Remove the existing chassis from the server rack.

Important

We strongly recommend using a server lift or that two people perform this task.

Step 2: Install New Components

1. Install the new chassis in the server rack.

Caution

To avoid warping the chassis frame, always keep it level while you insert it into the server rack. Never insert the chassis at an angle and don't apply excessive pressure to it.

2. Install the NVMe drives and the boot drive in the node.
3. Do one of the following:
 - If your replacement chassis comes with NICs, install the new NICs in the chassis and connect the network cabling to the NIC ports.
 - If your replacement chassis doesn't come with NICs, install and connect the existing NICs.
4. For the PSUs, do one of the following:
 - If your replacement chassis comes with PSUs, install the new PSUs in the chassis and connect the power cabling to the PSUs.
 - If your replacement chassis doesn't come with PSUs, install and connect the existing PSUs.
5. Boot by using the latest version of the Qumulo Core USB Drive Installer.
6. Select **[*] Perform maintenance**.
7. Select **[2] Perform automatic repair after part replacement (non-destructive)**.

The part replacement procedure runs and the **FVT passed!** message appears.

Note

In some cases, after the part replacement procedure, the message **FIX: Run the FVT flash command.** appears. Enter **1** as you would for a fixable issue to reboot the node and then repeat the part replacement procedure.

Quiver 1U Hybrid Gen2

Racking Your Quiver 1U Hybrid Gen2 Nodes

This section explains how to rack Quiver 1UH Gen2 nodes in a data center.

To Install the Rails in the Server Rack

⚠ Important

For square server rack holes, you must attach the square stud fully inside the square hole on the rack rail.

1. Adjust the chassis rails to the length of your server rack.
2. Line up each chassis rail with your server rack rail and push the clip on the rail in while sliding the studs into the mounting holes on the rack rail, until the studs click into place and the clip latches over the rack. This process is the same for the front and back of your rack.

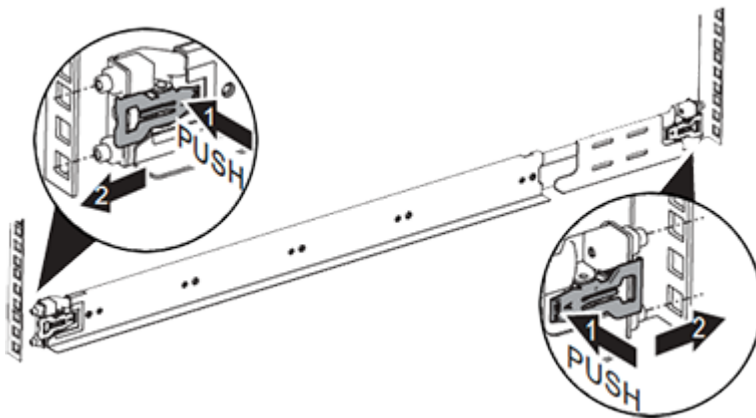

To Insert the Chassis into the Server Rack

⚠ Important

We strongly recommend using a server lift or that two people perform this task.

1. Place the chassis onto the rails and slide it into the server rack.

⚠ Caution

To avoid warping the chassis frame, always keep it level while you insert it into the server rack. Never insert the chassis at an angle and don't apply excessive pressure to it.

2. Attach the chassis to the rack by using one screw on each side on the front of the chassis.

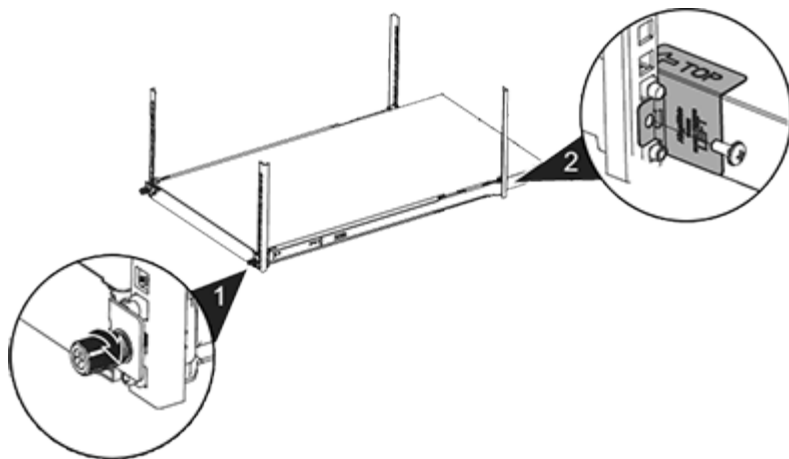

3. Attach the two stoppers marked L (left) and R (right) by using #10-32 × 13" screws on the back of the chassis.

To Remove the Chassis from the Server Rack

Perform the steps for inserting the chassis in reverse order.

Configuring the Intelligent Platform Management Interface (IPMI) and Wiring Your Quiver 1U Hybrid Gen2 Nodes

This section explains how to wire the out-of-band management (IPMI) port, 25 Gbps or 100 Gbps ports, and power on Quiver 1UH Gen2 nodes.

This platform uses a *unified networking configuration* in which the same NIC handles back-end and front-end traffic. In this configuration, each networking port provides communication with clients and between nodes. You can connect the NIC's ports to the same switch or to different switches.

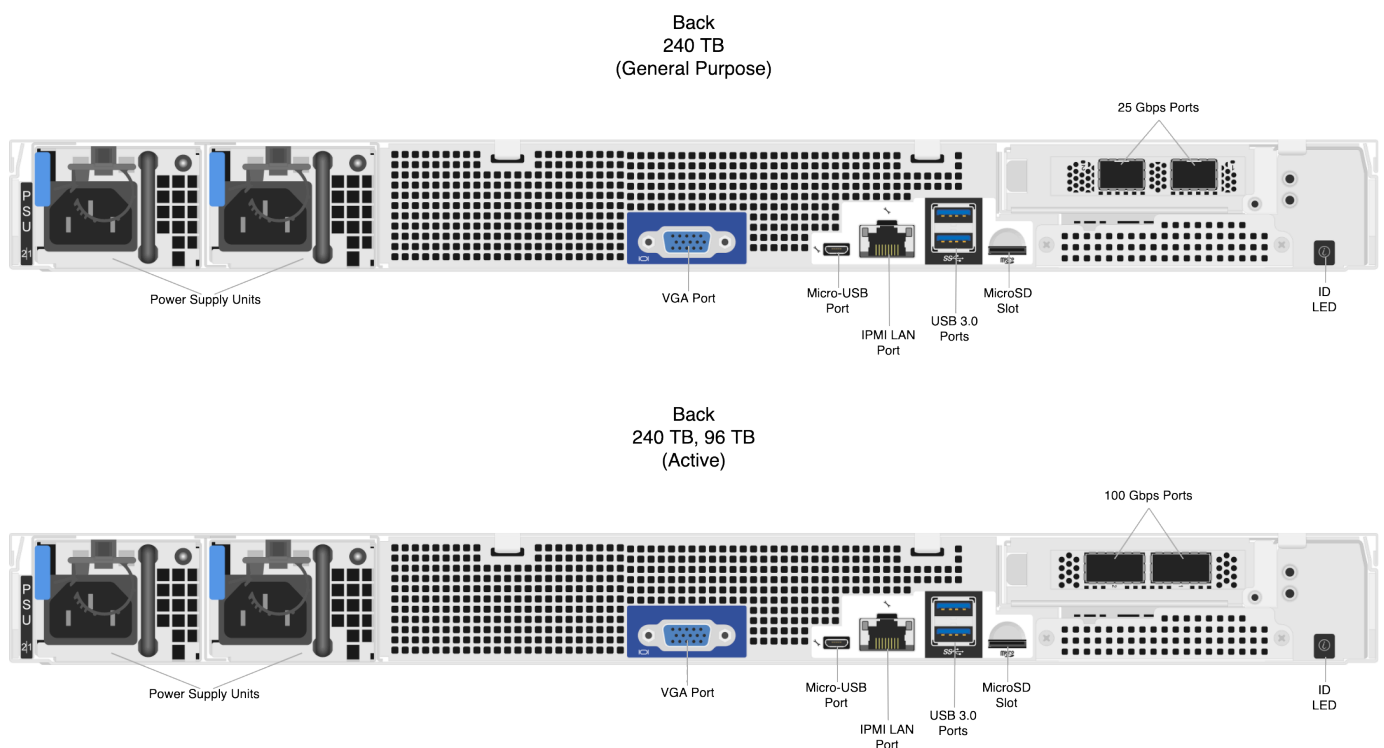

How the IPMI Port Works

The dedicated out-of-band management port allows functionality such as remote display, control, and power. The port uses the Intelligent Platform Management Interface (IPMI) protocol.

The IPMI port is located on the back of your node. For more information, see the documentation from your hardware vendor.

For more information, see [Default IPMI Usernames and Passwords](#)  on Qumulo Care.

Note

The IPMI username and password are unrelated to your Qumulo administrative credentials.

To configure the IPMI port, you must use the BMC UI. For more information, see the [BMC section in the Quiver 1U Hybrid Gen2 Service Guide \(p.107\)](#) .

To Configure the IPMI Port by Using ipmitool

Alternatively, you can configure the IPMI port by using `ipmitool`.

In the following examples, the `lan set 1` command specifies LAN channel 1.

1. To change the configuration from DHCP to static IP assignment, use the `ipsrc` subcommand. For example:

```
ipmitool lan set 1 ipsrc static
```

2. To set the IP address, use the `ipaddr` subcommand. For example:

```
ipmitool lan set 1 ipaddr 203.0.113.0
```

3. To set the subnet mask, use the `netmask` subcommand. For example:

```
ipmitool lan set 1 netmask 255.0.0.1
```

4. To set the default gateway, use the `defgw` subcommand. For example:

```
ipmitool lan set 1 defgw ipaddr 192.168.0.1
```

5. To enable Address Resolution Protocol (ARP), which Qumulo Core often requires for `ping` to function properly, use the `arp` subcommand. For example:

```
ipmitool lan set 1 arp respond on
```

6. To reset the BMC to allow the new configuration to take effect, run the `ipmitool mc reset cold` command.

Step 2: Connecting the 25 Gbps or 100 Gbps Ports

After you connect the iRMC port, connect your 25 Gbps or 100 Gbps ports (compatible with QSFP28 and QSFP56). There are two 25 Gbps or 100 Gbps ports on the back of your node. This platform uses a *unified networking configuration* in which the same NIC handles back-end and front-end traffic. In this configuration, each networking port provides communication with clients and between nodes. You can connect the NIC's ports to the same switch or to different switches.

✓ Tip

To identify the eth port, run the following command:

```
for i in /sys/class/net/eth*; \  
do echo $i; \  
cat $i/device/uevent | \  
grep -i pci_slot; \  
done
```

Step 3: Connecting the Power

After you connect your 25 Gbps or 100 Gbps ports, connect power to the node. There are two power sockets on the back of your node. To maximize redundancy, connect each PSU to a separate power supply or power distribution unit (PDU).

Creating and Configuring a Qumulo Cluster with Quiver 1U Hybrid Gen2 Nodes

This section explains how to prepare Quiver 1UH Gen2 nodes for creating a Qumulo cluster.

Step 1: Verify Your Node

1. Shut down your node and connect a display, a keyboard, and a mouse to it.
2. Plug the [Qumulo Core USB Drive Installer](#) into an available USB port on the node and then press the power button.

Step 2: Boot by Using the Qumulo Core USB Drive Installer

1. When the node powers on and begins to boot, on the QCT screen, press F11.

Note

The boot setting is persistent: When you boot from a USB drive once, the node continues to boot from the USB drive. After you finish installing Qumulo Core, remove the USB drive from the node.

2. On the **Please select boot device:** screen, select your USB drive (usually labeled with **UEFI OS**) and boot into it.

Step 3: Install Qumulo Core

After the node reboots, the Field Verification Tool runs automatically.

Select **[1] Factory reset (DESTROYS ALL DATA)** and then enter **DESTROY ALL DATA**.

When the FVT finishes, the **FVT passed!** message appears.

Qumulo Core is now installed on your node.

Fixable Issues During Installation

If the FVT finds fixable issues, it prompts you to auto-correct any detected issues, depending on your installation scenario. Issues that the FVT can auto-correct include the following:

- BIOS Configuration
 - Drive firmware
 - NIC mode
 - Boot order
1. To attempt auto-correction, select **[1] Run FVT Flash**. This will try to fix issues then reboot.

If the fixes are successful, the FVT reboots the node automatically.

2. To re-attempt verification, [boot by using the Qumulo Core USB Drive Installer \(page 166\)](#) and then continue the installation.

Non-Fixable Issues

If the FVT is unable to auto-correct any issues, the message **Not fixable issues were detected.** appears, providing reasons for failure.

For help with troubleshooting your node, [contact the Qumulo Care Team](#).

Step 4: Create and Configure Your Cluster

1. Review the **End User Agreement**, click **I agree to the End User Agreement**, and then click **Submit**.
2. Name your cluster.
3. On the **1. Set up cluster** page, select the nodes to add to your cluster.

As you select nodes, the installer updates the total capacity of your cluster at the bottom of the page.

Note

If any nodes are missing, confirm that they are powered on and connected to the same network.

4. Confirm that the individual nodes have the expected capacity.
5. On the **2. Confirm cluster protection level** page, Qumulo Core selects the recommended 2, 3, or 4-drive protection level based on your cluster size and node type.
6. If the **Customize Protection Level** option appears, you can increase your system resilience by selecting 3- or 4-drive protection.

⚠ Important

- Qumulo Core 6.1.0.1 and 6.1.1 support Adaptive Data Protection by letting you reconfigure your cluster's fault tolerance level and storage efficiency only when you add nodes to your cluster.

Depending on your cluster, Qumulo Core shows configuration options that offer better fault tolerance levels, better storage efficiency, or both benefits. To enable Adaptive Data Protection for your cluster, you must [contact the Qumulo Care Team](#).

- In Qumulo Core 6.1.2 (and higher), you can change your cluster's data protection configuration when you add or replace nodes by using the `qq` CLI.
- Using 3- or 4-drive protection reduces the total capacity of your cluster.

7. Enter a password for the administrative account and click **Create Cluster**.
8. To access the Qumulo Core Web UI, connect to any node by entering its IP address into a browser.

Drive Bay Mapping in Quiver 1U Hybrid Gen2 Nodes

This section explains the drive bay mapping in Quiver 1UH Gen2 nodes.

- For 240T and 96T nodes, your chassis contains 12 HDDs and 4 NVMe drives.
- For 48T nodes, your chassis contains 6 HDDs and 3 NVMe drives.

All Quiver 1UH Gen2 nodes contain one boot drive in an internal M.2 expansion slot.

HDD Drives

- For 240T and 96T nodes, all drive bays are populated.
- For 48T nodes, only the following bays are populated: 0, 3, 4, 7, 8, 11.

For more information, see [To Replace an HDD \(page 180\)](#).

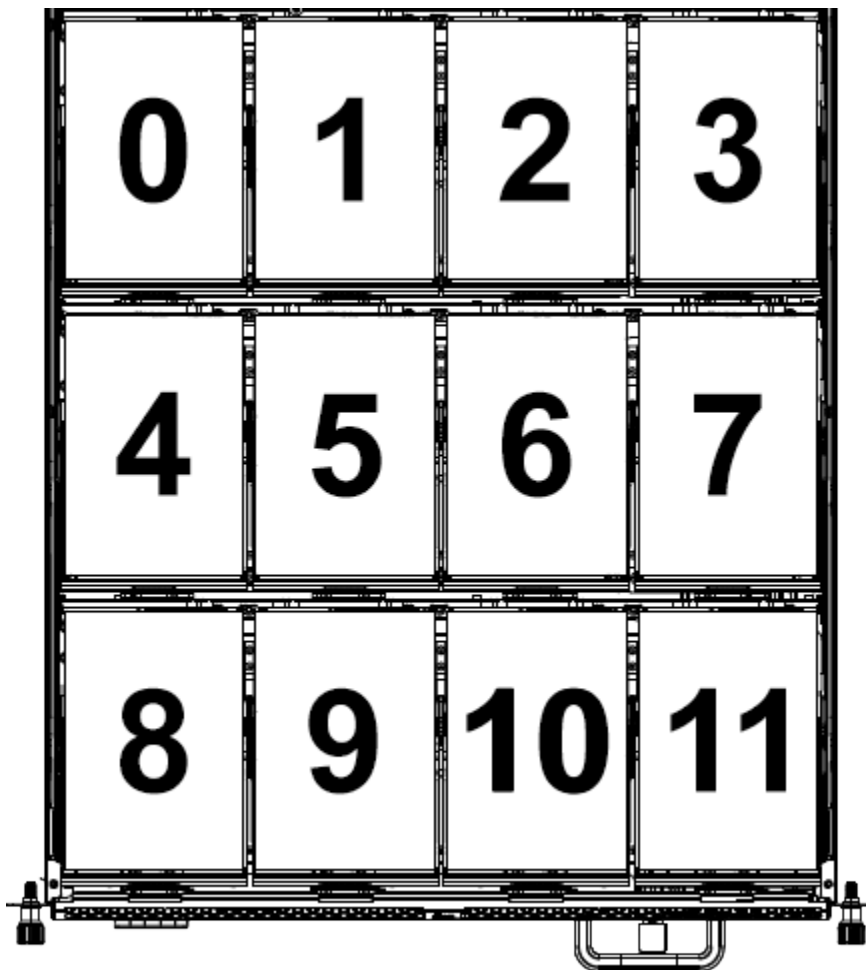

NVMe Drives

- For 240T and 96T nodes, all drive bays are populated.

- For 48T nodes, only the following drive bays are populated: 0, 1, 2.

⚠ Important

When replacing faulty drives, use only the originally populated drive bays.

For more information, see [To Replace an NVMe Drive \(page 177\)](#)

Front

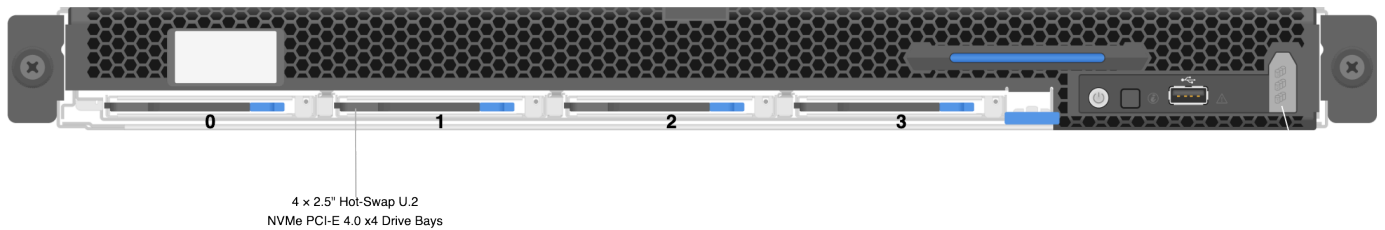

NVMe M.2 Boot Drive

The boot drive is located at the M.2 expansion slot at Riser Slot 4. For more information, see [To Replace an NVMe M.2 Boot Drive \(page 177\)](#).

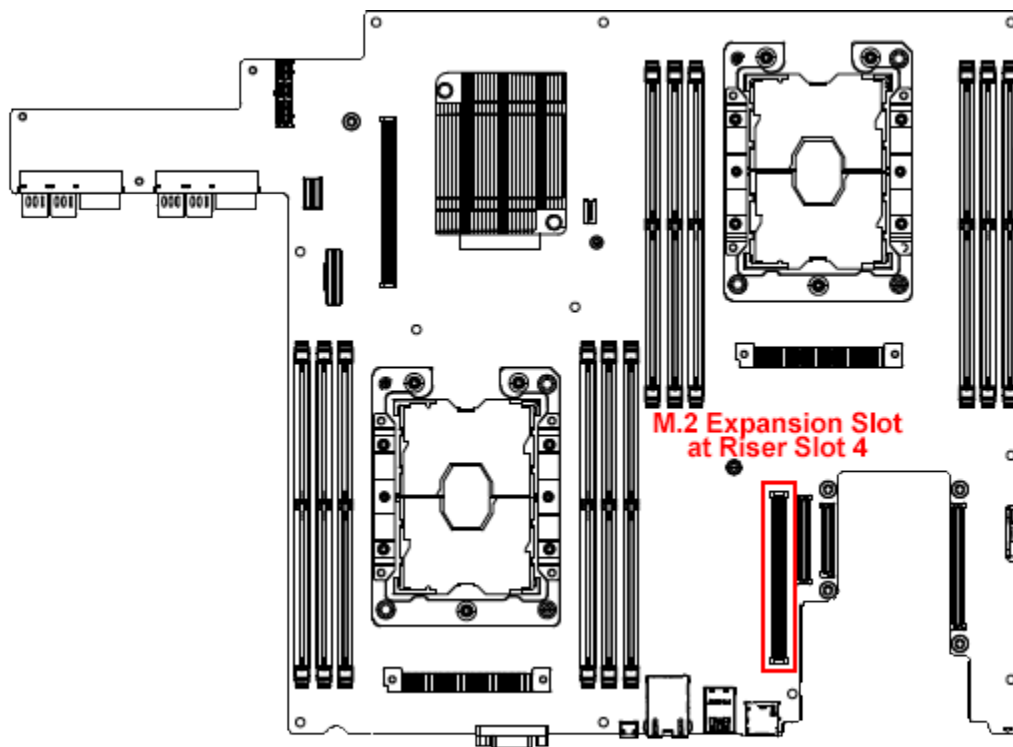

Panel LEDs on Quiver 1U Hybrid Gen2 Nodes

This section explains the LEDs on Quiver 1UH Gen2 nodes.

Front Panel LEDs and Buttons

On the front, right side of your node, there are four LEDs.

Label	Color and Behavior	Description
Power Button with LED	● (solid blue)	On
Power Button with LED	● (blinking blue)	Standby or sleep
ID LED	Off	No ID requested
ID LED	● (solid blue)	Selected unit ID
Status LED	Off	Operation normal
Status LED	● (solid amber)	DC off and critical error
Status LED	● (blinking amber)	DC on and critical error
HDD Row LED	Off	Operation normal
HDD Row LED	● (blinking amber)	Fault

NVMe Drive Carrier LEDs

Each NVMe drive carrier has one LED.

Color or Behavior	Description
● (solid blue)	Drive present
● (solid amber)	Drive failed
Off	Slot empty

Networking Your Quiver 1U Hybrid Gen2 Cluster

This section explains how to network a Quiver 1U Hybrid Gen2 cluster.

✓ Tip

To identify the eth port, run the following command:

```
for i in /sys/class/net/eth*; \
do echo $i; \
cat $i/device/uevent | \
grep -i pci_slot; \
done
```

Prerequisites

📘 Note

Before you create your Qumulo cluster, if your client environment requires Jumbo Frames (9,000 MTU), configure your switch to support a higher MTU.

Your node requires the following resources.

- A network switch with the following specifications:
 - Ethernet connectivity
 - Fully non-blocking architecture
 - IPv6 capability
- Compatible networking cables
- A sufficient number of ports for connecting all nodes to the same switch fabric
- One static IP for each node, for each defined VLAN

Recommended Configuration

This platform uses a *unified networking configuration* in which the same NIC handles back-end and front-end traffic. In this configuration, each networking port provides communication with clients and between nodes. You can connect the NIC's ports to the same switch or to different switches. However, for greater reliability, we recommend connecting both ports on every node to each switch.

We recommend the following configuration for your node.

- Your Qumulo MTU configured to match your client environment
- Two physical connections for each node, one connection for each redundant switch
- One Link Aggregation Control Protocol (LACP) port-channel for each network on each node, with the following configuration
 - Active mode
 - Slow transmit rate
 - Access port or trunk port with a native VLAN
- DNS servers
- A Network Time Protocol (NTP) server
- Firewall protocols or ports allowed for proactive monitoring
- Where N is the number of nodes, $N-1$ floating IP addresses for each node, for each client-facing VLAN

Connecting to Redundant Switches

For redundancy, we recommend connecting your cluster to dual switches. If either switch becomes inoperative, the cluster is still be accessible from the remaining switch.

- Connect the two NIC ports on your nodes to separate switches.
- The uplinks to the client network must equal the bandwidth from the cluster to the switch.
- The two ports form an LACP port channel by using a multi-chassis link aggregation group.
- Use an appropriate inter-switch link or virtual port channel.

Connecting to a Single Switch

You can connect a your cluster to a single switch. If this switch becomes inoperative, the entire cluster becomes inaccessible.

- Connect the two NIC ports on your nodes to a single switch.
- The uplinks to the client network must equal the bandwidth from the cluster to the switch.
- The two ports form an LACP port channel.

Four-Node Cluster Architecture Diagram

The following is the recommended configuration for a four-node cluster connected to an out-of-band management switch and redundant switches.

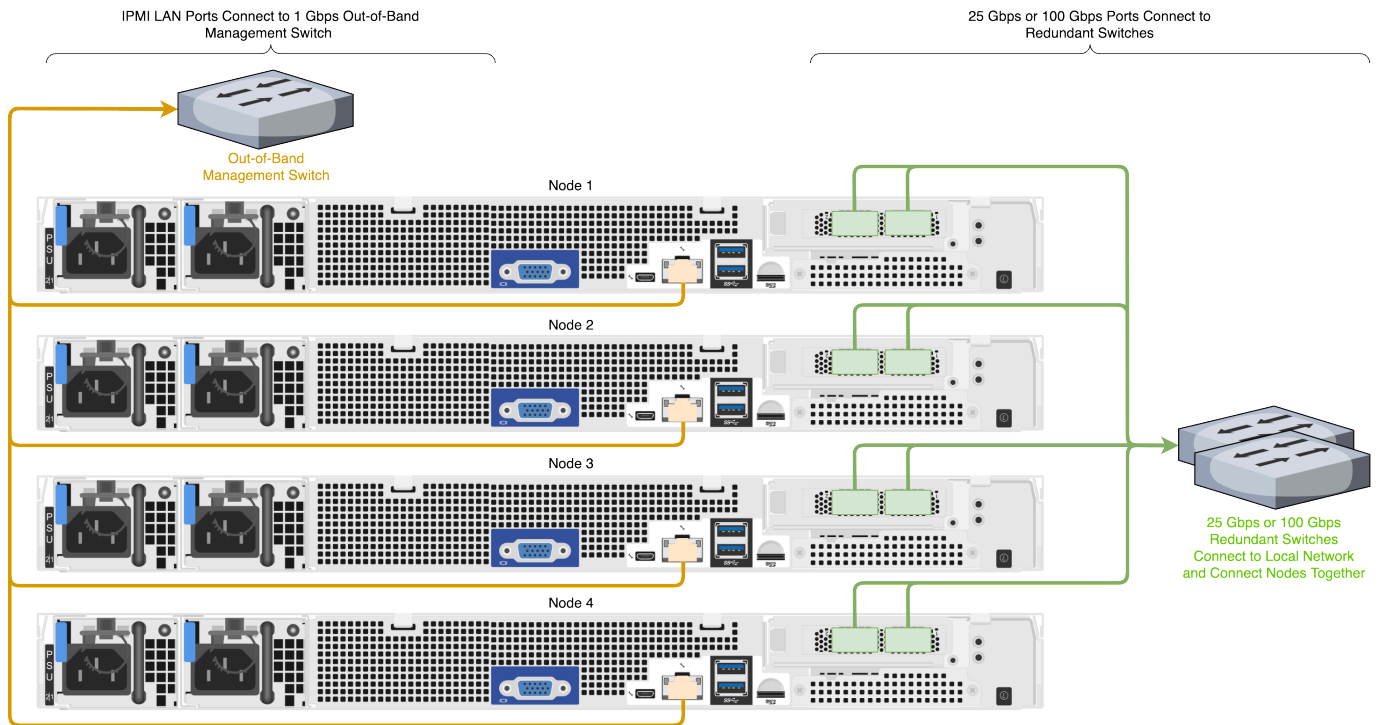

Replacing Hardware Components in Your Quiver 1U Hybrid Gen2 Nodes

This section explains how to replace hardware components in Quiver 1U Hybrid Gen2 nodes.

To Remove and Replace the Top Cover

Your Quiver 1UH Gen2 chassis has a label with instructions for removing the top cover.

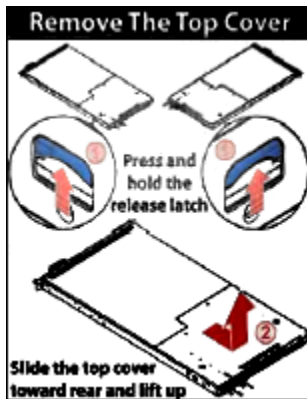

1. To remove the top cover, press the blue latches located near the back, on each side of the node, upwards and slide out the cover towards the front.



2. To replace the top cover, slide it towards the back, ensuring that the guide pin is fixed fully in the guide hole and the blue latches click into place.

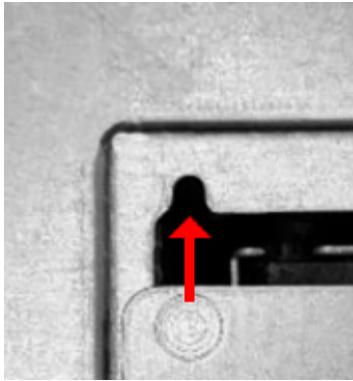

To Replace a PCI Express (PCIe) Riser Card

Your Quiver 1UH Gen2 chassis contains a PCIe riser card inserted vertically into the motherboard. The PCIe riser card holds the NIC and M.2 boot drive.

i Note

The PCIe riser card installation is toolless.

1. To replace this component, you must first power off the node.
2. To remove the existing PCIe riser card, pull it vertically out of the PCIe slot.

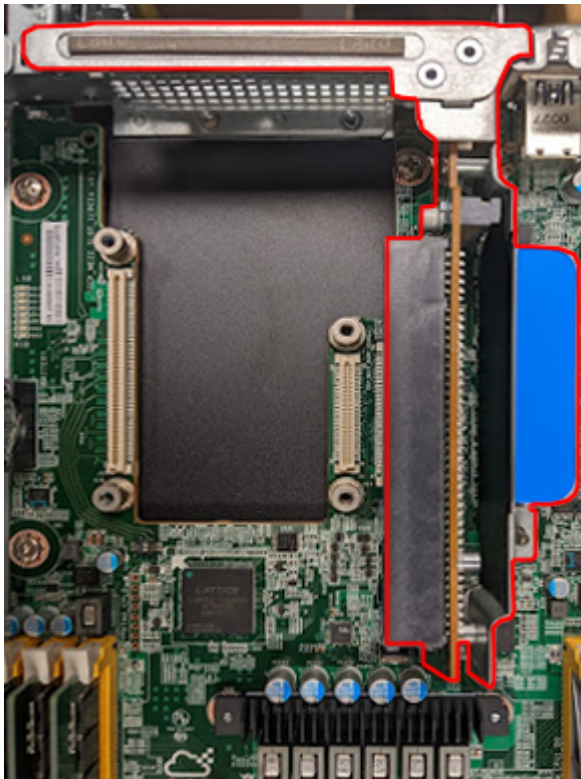

3. To install a replacement PCIe riser card, insert it vertically into the PCIe slot.

To Replace a NIC

Your Quiver 1UH Gen2 chassis contains a NIC inserted horizontally into the PCIe riser card.

i Note

Although the NIC installation is toolless, depending on the NIC that ships with your node model, you might have to replace the exterior-facing metal frame on your NIC with a different one. For more information, see [Technical Specifications \(page 0\)](#).

1. To replace this component, you must first power off the node.
2. [Remove the PCIe card from the motherboard. \(page 176\)](#)
3. Insert the NIC into the PCIe riser card horizontally.

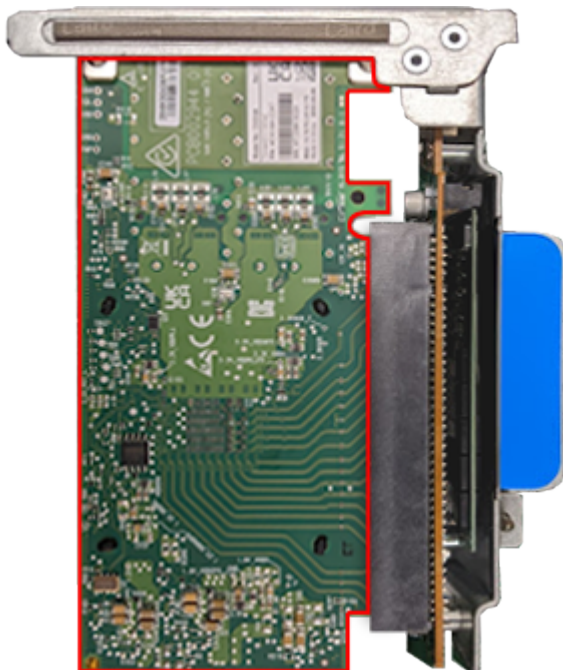

4. Insert the PCIe riser card vertically into the PCIe slot.

To Replace an M.2 Boot Drive

Your Quiver 1UH Gen2 chassis contains an NVMe boot drive inserted vertically into an M.2 expansion slot on the PCIe riser card. For more information, see [NVMe M.2 Boot Drive \(page 170\)](#).

1. To replace this component, you must first power off the node.
2. [Remove the PCIe card from the motherboard. \(page 176\)](#)
3. Remove the two diagonally placed screws that fasten the PCIe riser card's board to its bracket.

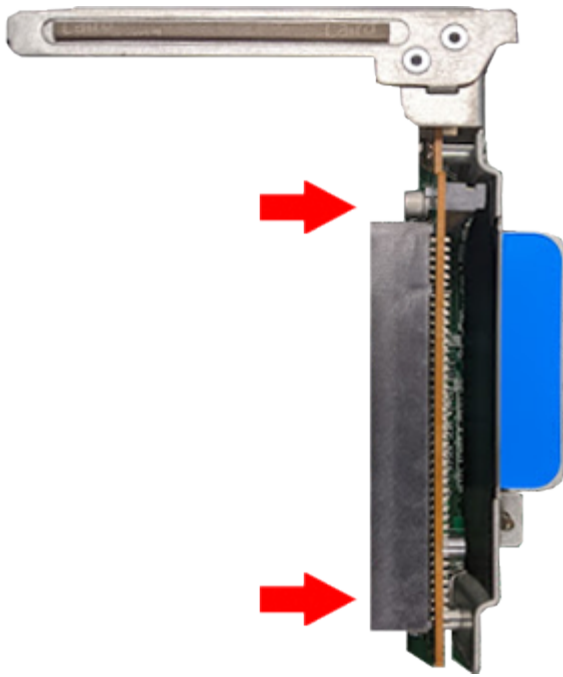

4. Insert the M.2 boot drive into the M.2 expansion slot on the PCIe riser card's board.



5. Reattach the PCIe riser card to its bracket so that the M.2 boot drive is located between the board and the bracket.

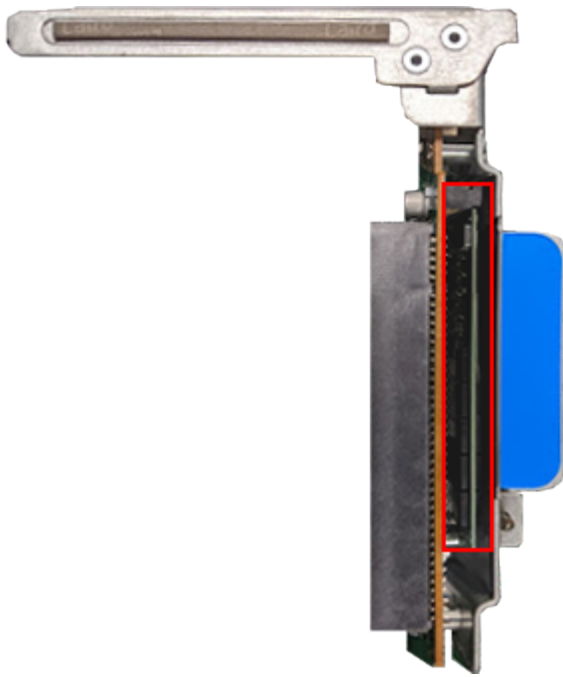

6. Insert the PCIe riser card vertically into the PCIe slot.

Initializing the Replacement Boot Drive

After you replace the boot drive, you must initialize the replacement boot drive by using the Qumulo Core Installer and then rebuild the replacement boot drive by using a script on the node in your cluster.

Step 1: Initialize the Replacement Boot Drive

✓ Tip

To get the correct version of the Qumulo Core Installer for the node in your cluster, [contact the Qumulo Care Team](#)

1. [Create a Qumulo Core USB Drive Installer \(page 10\)](#).
2. Power on your node, enter the boot menu, and select your USB drive.

The Qumulo Core Installer begins to run automatically.

3. When prompted, take the following steps:
 - a. Select **[x] Perform maintenance** .
 - b. Select **[1] Boot drive reset** and then follow the prompts.

The Qumulo Core Installer initializes the boot drive.

4. When the process is complete, the node is powered down automatically.

Step 2: Rebuild the Replacement Boot Drive

1. Power on your node and log in to the node by using the `qq` CLI.
2. To get `root` privileges, run the `sudo qsh` command.
3. To stop the Qumulo Networking Services, run the `service qumulo-networking stop` command.
4. To configure the IP address for the node, run the `ip addr add` command and specify the node's IP address. For example:

```
ip addr add 203.0.113.0/CDR dev bond0
```

5. Ensure that the node can ping other nodes in the cluster.
6. Run the `rebuild_boot_drive.py` script and specify the IP address of *another node* in the cluster, the ID of the node whose boot drive has been replaced, and the password of the administrative account of the cluster. For example:

Note

If your password includes special characters such as the parenthesis (`()`) or the asterisk (`*`), use the backslash (`\`) to escape these characters.

```
/opt/qumulo/rebuild_boot_drive.py \  
  --address 203.0.113.1 \  
  --node-id 2 \  
  --username admin \  
  --password my\ (Special\ *Password
```

Follow the prompts.

7. When the process is complete, reboot the node.

To Replace an HDD

Your Quiver 1UH Gen2 chassis contains 12 or 6 HDDs. For more information, see [HDD Drives \(page 169\)](#).

Note

- You can replace this component without powering off the node.
- Sliding out the tray that holds the HDD carriers doesn't interfere with your node's operation.

1. Slide the tray with the HDD carriers out of the chassis.

Caution

Don't place any weight on the tray with the HDD carriers while the tray is extended.

2. Lift up the drive carrier handle and remove the carrier with the HDD from the tray.
3. Remove the three screws from the existing HDD.
4. Remove the existing HDD from its carrier.
5. Install the new HDD in the carrier.
6. Install the three screws in the new HDD.
7. Insert the carrier with the new HDD into the tray and lower the drive carrier handle.
8. Slide the tray with the HDD carriers into the chassis.

To Replace an NVMe Drive

Your Quiver 1UH Gen2 chassis contains 4 or 3 NVMe drives. For more information, see [NVMe Drives \(page 169\)](#).

1. To replace this component, you must first power off the node.
2. To remove the existing NVMe drive, pull out the SSD bracket while pressing the blue latch.
3. Remove the four screws from the existing NVMe drive.
4. Remove the existing NVMe drive from the SSD bracket.
5. Install the new NVMe drive in the SSD bracket.
6. Install the four screws in the new NVMe drive.
7. Insert the SSD bracket with the new NVMe drive into the chassis until the blue latch snaps into place.

To Replace a Power Supply Unit (PSU)

Your Quiver 1UH Gen2 chassis contains two PSUs.

Note

You can replace this component without powering off the node.

1. Unfasten the power cord latch and remove the power cord from the existing PSU.
2. To remove the existing PSU, press the blue latch while pulling on the black handle.
3. Slide the new PSU into the chassis.
4. Fasten the power cord latch to the power cord.

To Replace a Fan Module

Your Quiver 1UH Gen2 chassis has two three-fan modules. The fans are marked L (left), M (middle), and R (right). Each module has six rubber clips on each side and latches that hold cables in place.



1. To replace this component, you must first power off the node.
2. Remove the air duct from the existing fan module.
3. Remove the connector cable from the motherboard.
4. Remove the rubber clips from the existing fan module and the cables from their latches.
5. To remove the existing fan module, pull it from its cage.
6. Slide the new fan module into its cage.
7. Install the rubber clips in the new fan module and place cables into their latches.
8. Plug the connector cable into the motherboard.
9. Replace the air duct onto the new fan module.

To Replace a DIMM

Your Quiver 1UH Gen2 chassis has 12 DIMM slots, with a locking latch on each side of each DIMM.

1. To replace this component, you must first power off the node.
2. To remove an existing DIMM, press down on the latches and pull the module upwards.
3. Match the notch on the new DIMM with the protrusion on the DIMM slot.
4. Firmly press the DIMM into the slot until it clicks in and the latches lock.

i Note

To identify which DIMM failed, you must use the baseboard management controller (BMC) on the node or another hardware monitoring solution.

Replacing the Node Chassis

⚠ Important

After you perform a chassis swap, you must reconfigure the IPMI settings for your node.

Step 1: Remove the Existing Components

1. At the back of the node, disconnect the power cabling from both power supply units (PSUs) and [remove both existing PSUs \(page 181\)](#) from the node.
2. Disconnect the network cabling from the NIC port and [remove the existing NIC \(page 177\)](#) from the node.
3. Remove the existing [HDDs \(page 180\)](#), [NVMe drives \(page 181\)](#), and the [NVMe M.2 boot drive \(page 177\)](#) from the node.
4. [Remove the existing chassis \(page 162\)](#) from the server rack.

⚠ Important

We strongly recommend using a server lift or that two people perform this task.

Step 2: Install New Components

1. Install the new chassis in the server rack.

! Caution

To avoid warping the chassis frame, always keep it level while you insert it into the server rack. Never insert the chassis at an angle and don't apply excessive pressure to it.

2. Install the existing HDDs, NVMe drives, and the boot drive in the node.
3. For the NIC, do one of the following:
 - If your replacement chassis comes with a NIC, install the new NIC in the chassis and connect the network cabling to the NIC ports.
 - If your replacement chassis doesn't come with a NIC, install and connect the existing NIC.
4. For the PSUs, do one of the following:
 - If your replacement chassis comes with PSUs, install the new PSUs in the chassis and connect the power cabling to the PSUs.
 - If your replacement chassis doesn't come with PSUs, install and connect the existing PSUs.
5. Boot by using the latest version of the Qumulo Core USB Drive Installer.
6. Select [*] Perform maintenance.
7. Select [2] Perform automatic repair after part replacement (non-destructive).

The part replacement procedure runs and the FVT **passed!** message appears.

i Note

In some cases, after the part replacement procedure, the message **FIX: Run the FVT flash command.** appears. Enter 1 as you would for a fixable issue to reboot the node and then repeat the part replacement procedure.

Quiver 2U Hybrid Gen2

Configuring the Intelligent Platform Management Interface (IPMI) and Wiring Your Quiver 2U Hybrid Gen2 Nodes

This section explains how to wire the out-of-band management (IPMI) port, 25 Gbps or 100 Gbps ports, and power on Quiver 2UH Gen2 nodes.

This platform uses a *unified networking configuration* in which the same NIC handles back-end and front-end traffic. In this configuration, each networking port provides communication with clients and between nodes. You can connect the NIC's ports to the same switch or to different switches.



How the IPMI Port Works

The dedicated out-of-band management port allows functionality such as remote display, control, and power. The port uses the Intelligent Platform Management Interface (IPMI) protocol.

The IPMI port is located on the back of your node. For more information, see the documentation from your hardware vendor.

For more information, see [Default IPMI Usernames and Passwords](#)  on Qumulo Care.

Note

The IPMI username and password are unrelated to your Qumulo administrative credentials.

To configure the IPMI port, you must use the BMC UI.

To Configure the IPMI Port by Using `ipmitool`

Alternatively, you can configure the IPMI port by using `ipmitool`.

In the following examples, the `lan set 1` command specifies LAN channel 1.

1. To change the configuration from DHCP to static IP assignment, use the `ipsrc` subcommand. For example:

```
ipmitool lan set 1 ipsrc static
```

2. To set the IP address, use the `ipaddr` subcommand. For example:

```
ipmitool lan set 1 ipaddr 203.0.113.0
```

3. To set the subnet mask, use the `netmask` subcommand. For example:

```
ipmitool lan set 1 netmask 255.0.0.1
```

4. To set the default gateway, use the `defgw` subcommand. For example:

```
ipmitool lan set 1 defgw ipaddr 192.168.0.1
```

5. To enable Address Resolution Protocol (ARP), which Qumulo Core often requires for `ping` to function properly, use the `arp` subcommand. For example:

```
ipmitool lan set 1 arp respond on
```

6. To reset the BMC to allow the new configuration to take effect, run the `ipmitool mc reset cold` command.

Step 2: Connecting the 25 Gbps or 100 Gbps Ports

After you connect the iRMC port, connect your 25 Gbps or 100 Gbps ports (compatible with QSFP28 and QSFP56). There are two 25 Gbps or 100 Gbps ports on the back of your node. This platform uses a *unified networking configuration* in which the same NIC handles back-end and front-end traffic. In this configuration, each networking port provides communication with clients and between nodes. You can connect the NIC's ports to the same switch or to different switches.

✓ Tip

To identify the eth port, run the following command:

```
for i in /sys/class/net/eth*; \  
do echo $i; \  
cat $i/device/uevent | \  
grep -i pci_slot; \  
done
```

Step 3: Connecting the Power

After you connect your 25 Gbps or 100 Gbps ports, connect power to the node. There are two power sockets on the back of your node. To maximize redundancy, connect each PSU to a separate power supply or power distribution unit (PDU).

Creating and Configuring a Qumulo Cluster with Quiver 2U Hybrid Gen2 Nodes

This section explains how to prepare Quiver 2UH Gen2 nodes for creating a Qumulo cluster.

Step 1: Verify Your Node

1. Shut down your node and connect a display, a keyboard, and a mouse to it.
2. Plug the [Qumulo Core USB Drive Installer](#) into an available USB port on the node and then press the power button.

Step 2: Boot by Using the Qumulo Core USB Drive Installer

1. When the node powers on and begins to boot, enter the boot menu.

Note

- The boot setting is persistent: When you boot from a USB drive once, the node continues to boot from the USB drive. After you finish installing Qumulo Core, remove the USB drive from the node.
- Depending on your node configuration, it might take longer than usual to boot up for the first time.

2. On the boot device selection screen, select your USB drive (usually labeled with **UEFI OS**) and boot into it.

The Qumulo Core installation begins.

Step 3: Create and Configure Your Cluster

Important

If only one of the networks is connected and operational during the cluster creation process, Qumulo Core deploys with the unified networking configuration.

1. Review the **End User Agreement**, click **I agree to the End User Agreement**, and then click **Submit**.
2. Name your cluster.
3. On the **1. Set up cluster** page, select the nodes to add to your cluster.

As you select nodes, the installer updates the total capacity of your cluster at the bottom of the page.

Note

If any nodes are missing, confirm that they are powered on and connected to the same network.

4. Confirm that the individual nodes have the expected capacity.
5. On the **2. Confirm cluster protection level** page, Qumulo Core selects the recommended 2, 3, or 4-drive protection level based on your cluster size and node type.
6. Enter a password for the administrative account and click **Create Cluster**.
7. To access the Qumulo Core Web UI, connect to any node by entering its IP address into a browser.

Drive Bay Mapping in Quiver 2U Hybrid Gen2 Nodes

This section explains the drive bay mapping in Quiver 2UH Gen2 nodes.

The Quiver 2UH Gen2 chassis contains 24 HDD drives in internal drawers, 6 NVMe drives at the back of the node, and one boot drive in an internal M.2 expansion slot.

✓ Tip

- To check that the node has detected all of the drives, run the following command:

```
/opt/MegaRAID/storcli/storcli64 /c0 show | \  
grep "Physical"
```

- To show the number of detected NVMe drives, run the `nvme list` command.

Internal HDD Drives

The HDD drives in the Quiver 2UH Gen2 chassis are located in three drawers.

Drawer 1 (Drives 1-8)

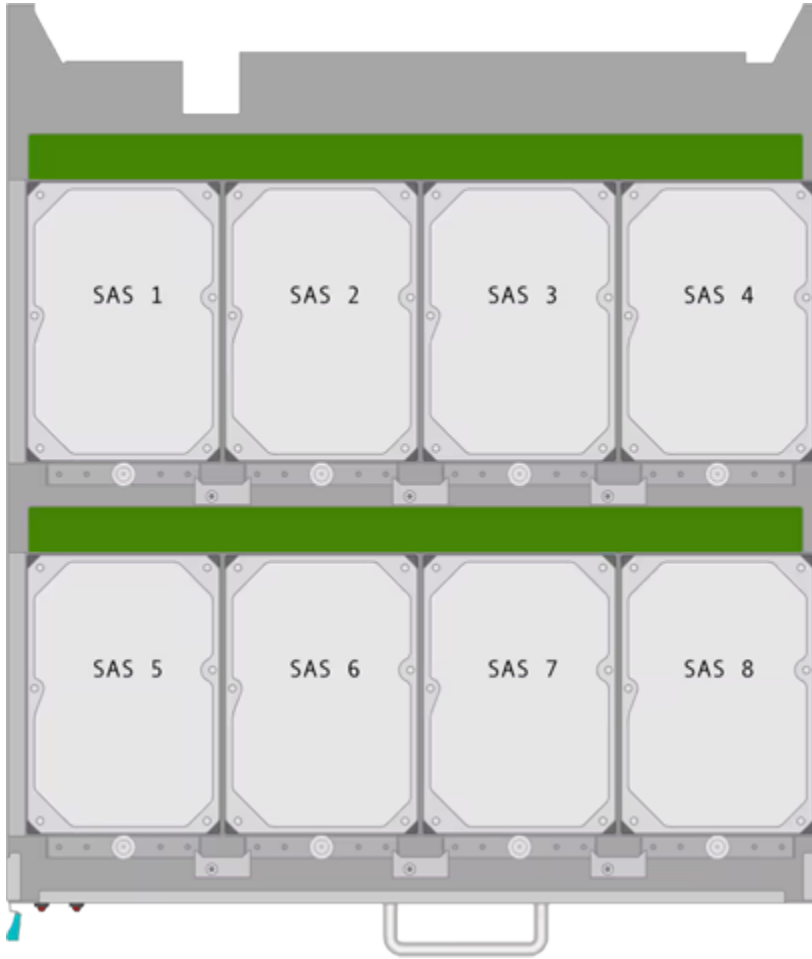

Drawer 2 (Drives 9-16)

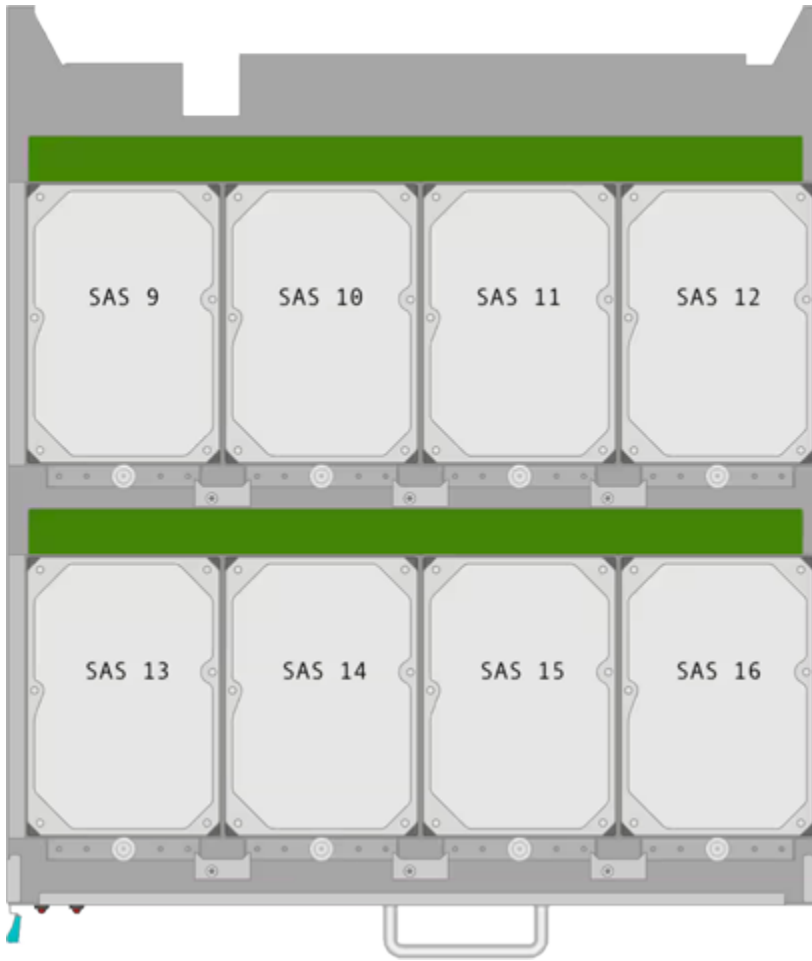

Drawer 3 (Drives 17-24)

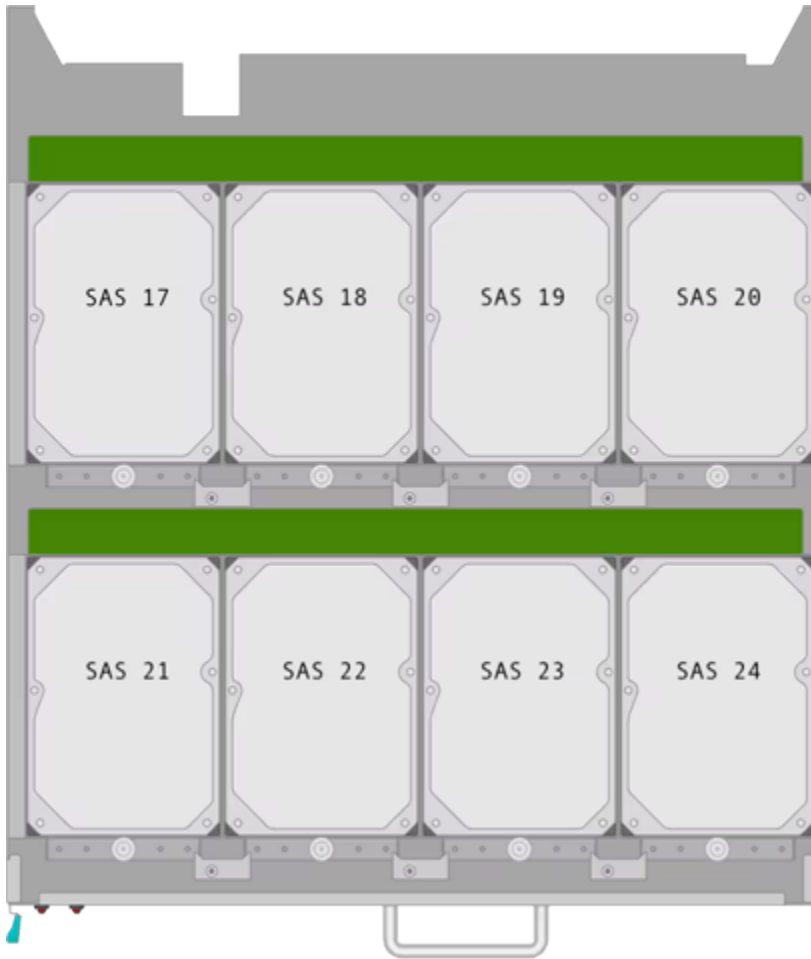

Rear NVMe Drives

The NVMe drives in the Quiver 2UH Gen2 are located at the back of the node.



NVMe M.2 Boot Drive

The boot drive is located at the M.2 expansion slot at Riser Slot 1.

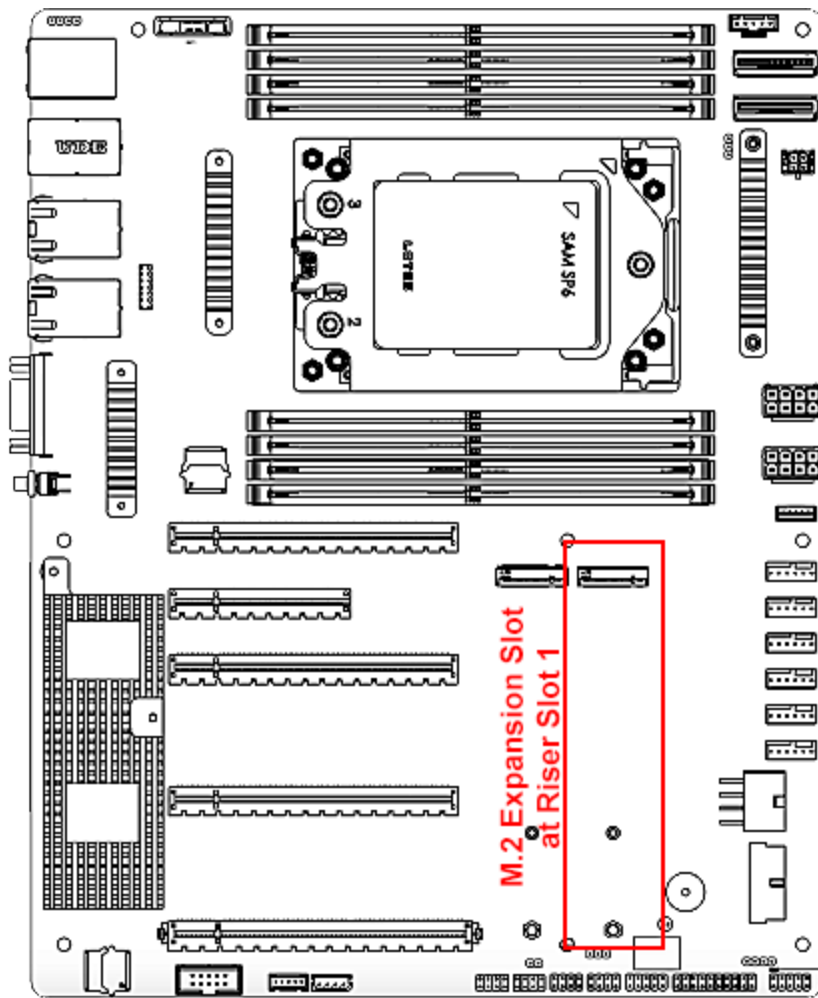

Panel LEDs on Quiver 2U Hybrid Gen2 Nodes

This section explains the LEDs on Quiver 2UH Gen2 nodes.

Front and Rear Panel LEDs and Buttons

For information about the front and rear panel LEDs and buttons, [Front Panel and Rear Panel \(p. 11\)](#)  in the documentation provided to Qumulo by AIC.

Networking Your Quiver 2U Hybrid Gen2 Cluster

This section explains how to network a Quiver 2U Hybrid Gen2 cluster.

✓ Tip

To identify the eth port, run the following command:

```
for i in /sys/class/net/eth*; \
do echo $i; \
cat $i/device/uevent | \
grep -i pci_slot; \
done
```

Prerequisites

📘 Note

Before you create your Qumulo cluster, if your client environment requires Jumbo Frames (9,000 MTU), configure your switch to support a higher MTU.

Your node requires the following resources.

- A network switch with the following specifications:
 - Ethernet connectivity
 - Fully non-blocking architecture
 - IPv6 capability
- Compatible networking cables
- A sufficient number of ports for connecting all nodes to the same switch fabric
- One static IP for each node, for each defined VLAN

Recommended Configuration

This platform uses a *unified networking configuration* in which the same NIC handles back-end and front-end traffic. In this configuration, each networking port provides communication with clients and between nodes. You can connect the NIC's ports to the same switch or to different switches. However, for greater reliability, we recommend connecting both ports on every node to each switch.

We recommend the following configuration for your node.

- Your Qumulo MTU configured to match your client environment
- Two physical connections for each node, one connection for each redundant switch
- One Link Aggregation Control Protocol (LACP) port-channel for each network on each node, with the following configuration
 - Active mode
 - Slow transmit rate
 - Access port or trunk port with a native VLAN
- DNS servers
- A Network Time Protocol (NTP) server
- Firewall protocols or ports allowed for proactive monitoring
- Where N is the number of nodes, $N-1$ floating IP addresses for each node, for each client-facing VLAN

Connecting to Redundant Switches

For redundancy, we recommend connecting your cluster to dual switches. If either switch becomes inoperative, the cluster is still be accessible from the remaining switch.

- Connect the two NIC ports on your nodes to separate switches.
- The uplinks to the client network must equal the bandwidth from the cluster to the switch.
- The two ports form an LACP port channel by using a multi-chassis link aggregation group.
- Use an appropriate inter-switch link or virtual port channel.

Connecting to a Single Switch

You can connect a your cluster to a single switch. If this switch becomes inoperative, the entire cluster becomes inaccessible.

- Connect the two NIC ports on your nodes to a single switch.
- The uplinks to the client network must equal the bandwidth from the cluster to the switch.
- The two ports form an LACP port channel.

Four-Node Cluster Architecture Diagram

The following is the recommended configuration for a four-node cluster connected to an out-of-band management switch and redundant switches.

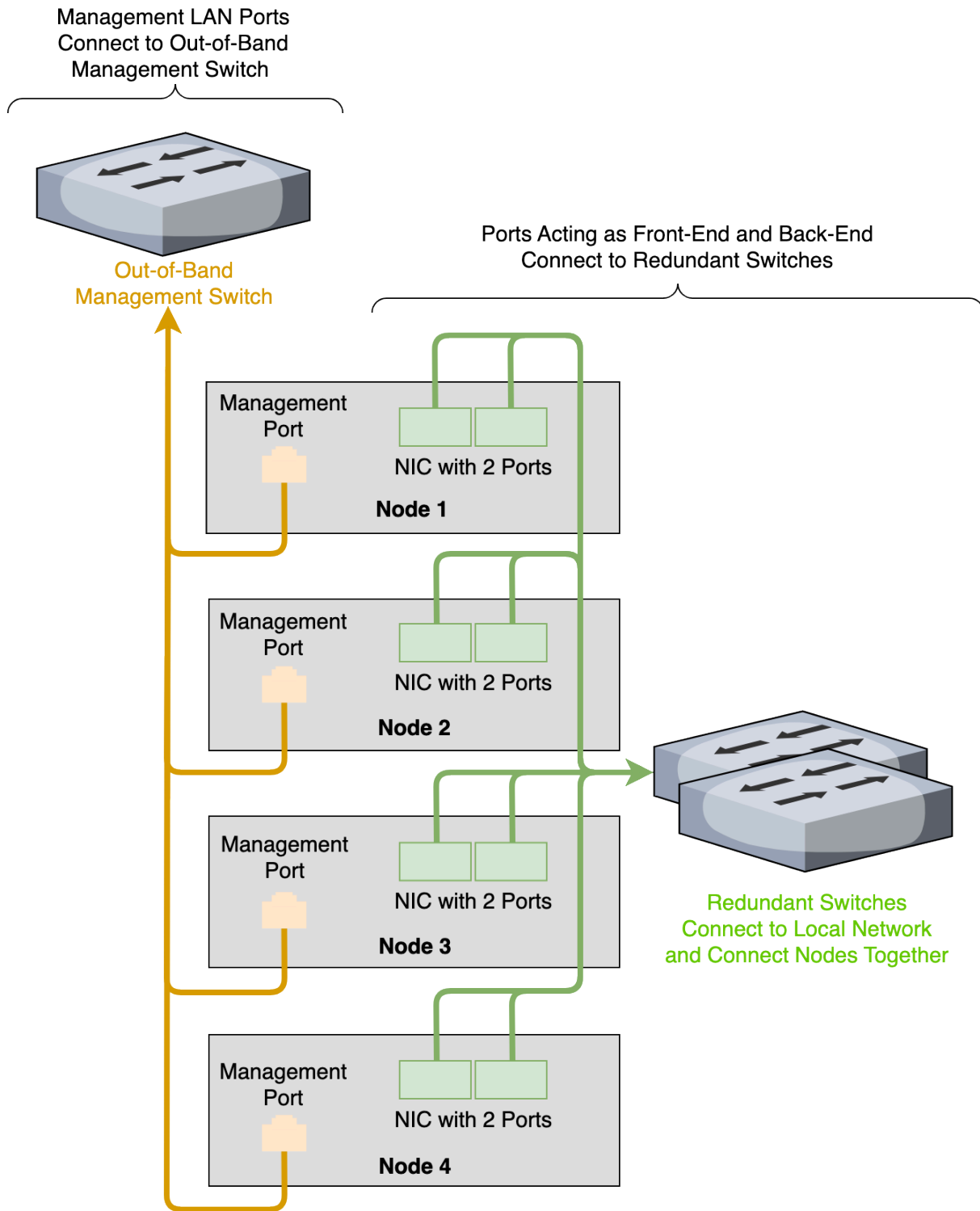

Replacing Hardware Components in Your Quiver 2U Hybrid Gen2 Nodes

This section explains how to replace hardware components in Quiver 2U Hybrid Gen2 nodes.

For detailed hardware replacement instructions, see [RSC-2MS Rackmount Chassis User's Manual](#)  in the documentation provided to Qumulo by AIC.

Important

Before installing your Quiver 2UH Gen2 node in a server rack, you must remove the shipping screws from the node.

Removing and Replacing the Top Cover

Follow the instructions in the SC-2MS Rackmount Chassis User's Manual: [Top Cover \(p. 13\)](#) .

Initializing the Replacement Boot Drive

After you replace the boot drive, you must initialize the replacement boot drive by using the Qumulo Core Installer and then rebuild the replacement boot drive by using a script on the node in your cluster. For more information, see [NVMe M.2 Boot Drive \(page 193\)](#).

Step 1: Initialize the Replacement Boot Drive

Tip

To get the correct version of the Qumulo Core Installer for the node in your cluster, [contact the Qumulo Care Team](#)

1. [Create a Qumulo Core USB Drive Installer \(page 10\)](#).
2. Power on your node, enter the boot menu, and select your USB drive.

The Qumulo Core Installer begins to run automatically.

3. When prompted, take the following steps:
 - a. Select **[x] Perform maintenance**.
 - b. Select **[1] Boot drive reset** and then follow the prompts.

The Qumulo Core Installer initializes the boot drive.

4. When the process is complete, the node is powered down automatically.

Step 2: Rebuild the Replacement Boot Drive

1. Power on your node and log in to the node by using the `qq` CLI.
2. To get `root` privileges, run the `sudo qsh` command.
3. To stop the Qumulo Networking Services, run the `service qumulo-networking stop` command.
4. To configure the IP address for the node, run the `ip addr add` command and specify the node's IP address. For example:

```
ip addr add 203.0.113.0/CDR dev bond0
```

5. Ensure that the node can ping other nodes in the cluster.
6. Run the `rebuild_boot_drive.py` script and specify the IP address of *another node* in the cluster, the ID of the node whose boot drive has been replaced, and the password of the administrative account of the cluster. For example:

Note

If your password includes special characters such as the parenthesis (`()`) or the asterisk (`*`), use the backslash (`\`) to escape these characters.

```
/opt/qumulo/rebuild_boot_drive.py \  
  --address 203.0.113.1 \  
  --node-id 2 \  
  --username admin \  
  --password my\ (Special\ *Password
```

Follow the prompts.

7. When the process is complete, reboot the node.

Replacing an HDD Drive

Your Quiver 2UH Gen2 chassis contains 24 HDDs. For more information about drive location and mapping, see [Internal HDD Drives \(page 190\)](#).

Replacing an NVMe Drive

Your Quiver 2UH Gen2 chassis contains 6 NVMe drives. For more information about drive location and mapping, see [Rear NVMe Drives \(page 193\)](#).

Replacing a Power Supply Unit (PSU)

Follow the instructions in the SC-2MS Rackmount Chassis User's Manual: [Power Supply Unit Module \(p. 14\)](#) .

Replacing a Fan Module

Follow the instructions in the SC-2MS Rackmount Chassis User's Manual: [Fan Module \(p. 15\)](#) .

To Replace the Node Chassis

Important

After you perform a chassis swap, you must reconfigure the IPMI settings for your node.

1. Remove the existing HDD and NVMe drives, the boot drive, and the NIC from the chassis.
2. Install the existing components in the new chassis.
3. Boot by using the latest version of the Qumulo Core USB Drive Installer.
4. Select [*] Perform maintenance.
5. Select [2] Perform automatic repair after part replacement (non-destructive).

Follow the prompts to complete the chassis replacement.

Supermicro A+ ASG-1014S-ACR12N4H

Racking Your Supermicro A+ ASG-1014S-ACR12N4H Nodes

This section describes how to use the toolless rail system to attach the rails to a server rack and install Supermicro 1014S nodes in a data center.

Important

The Supermicro A+ WIO 1114S-WN10RT platform has reached its End of Life (EoL) on May 23, 2025. For more information about End of Platform Support (EoPS), contact [Supermicro support](#).

Using the Toolless Rail System

Supermicro 1014S nodes don't require any tools for attaching rails to your server rack. For more information, see [The Toolless Rail System](#) in the Supermicro documentation.

To Insert the Chassis

For information about inserting the Supermicro 1014S node chassis into the server rack, see [Sliding the Chassis onto the Rack Rails](#) in the Supermicro documentation.

To Remove the Chassis

The Supermicro 1014S node chassis rests on the inner rail lip of the left and right rails. Two thumb screws secure the chassis to the server rack.

1. Disconnect any cables from the chassis.
2. Remove one screw from each side of the front of the chassis.
3. Pull the chassis out from the server rack.
4. (Optional) To remove the toolless rails from your server rack completely, see [Removing the Rails](#) in the Supermicro documentation.

Configuring the Intelligent Platform Management Interface (IPMI) and Wiring Your Supermicro A+ ASG-1014S-ACR12N4H Nodes

This section explains how to wire the out-of-band management (IPMI) port, 25 Gbps or 100 Gbps ports, and power on Supermicro 1014S nodes.

⚠ Important

The Supermicro A+ WIO 1114S-WN10RT platform has reached its End of Life (EoL) on May 23, 2025. For more information about End of Platform Support (EoPS), contact [Supermicro support](#).

This platform uses a *unified networking configuration* in which the same NIC handles back-end and front-end traffic. In this configuration, each networking port provides communication with clients and between nodes. You can connect the NIC's ports to the same switch or to different switches.

📘 Note

The two rightmost Ethernet ports on the back of your node are unused.

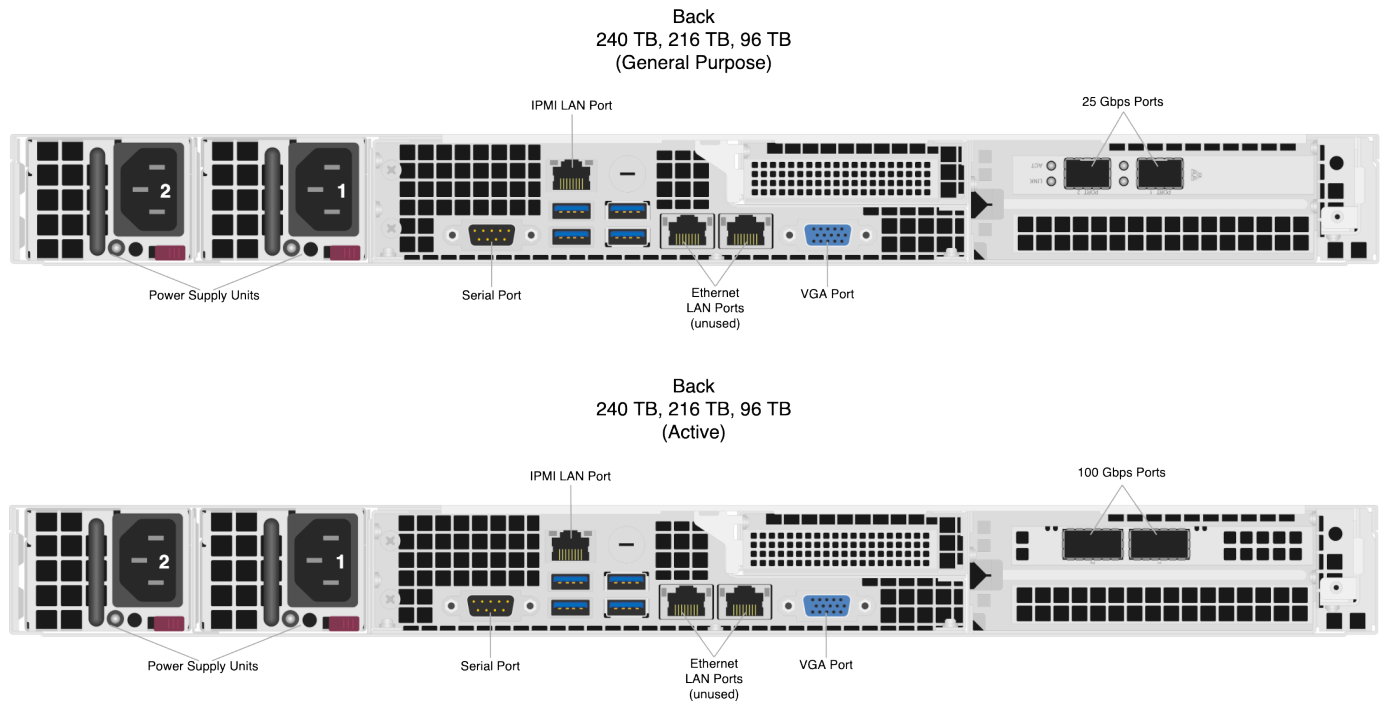

How the IPMI Port Works

The dedicated out-of-band management port allows functionality such as remote display, control, and power. The port uses the Intelligent Platform Management Interface (IPMI) protocol.

The IPMI port is located on the back of your node. For more information, see the documentation from your hardware vendor.

For more information, see [Default IPMI Usernames and Passwords](#)  on Qumulo Care.

Note

The IPMI username and password are unrelated to your Qumulo administrative credentials.

To configure the IPMI port, you must use the IPMI Management Utility installed on the motherboard. For more information, see [Supermicro BMC User Guide X12](#).

Step 2: Connecting the 25 Gbps or 100 Gbps Ports

After you connect the IPMI port, connect your 25 Gbps or 100 Gbps ports (compatible with QSFP28 and QSFP56). There are two 25 Gbps or 100 Gbps ports on the back of your node. This platform uses a *unified networking configuration* in which the same NIC handles back-end and front-end traffic. In this configuration, each networking port provides communication with clients and between nodes. You can connect the NIC's ports to the same switch or to different switches.

Tip

To identify the eth port, run the following command:

```
for i in /sys/class/net/eth*; \
do echo $i; \
cat $i/device/uevent | \
grep -i pci_slot; \
done
```

Step 3: Connecting the Power

After you connect your 25 Gbps or 100 Gbps ports, connect power to the node. There are two power sockets on the back of your node. To maximize redundancy, connect each PSU to a separate power supply or power distribution unit (PDU).

Creating and Configuring a Qumulo Cluster with Supermicro A+ ASG-1014S-ACR12N4H Nodes

This section explains how to prepare Supermicro 1014S nodes for creating a Qumulo cluster.

Important

The Supermicro A+ WIO 1114S-WN10RT platform has reached its End of Life (EoL) on May 23, 2025. For more information about End of Platform Support (EoPS), contact [Supermicro support](#).

Step 1: Verify Your Node

1. Shut down your node and connect a display, a keyboard, and a mouse to it.
2. Plug the [Qumulo Core USB Drive Installer](#) into an available USB port on the node and then press the power button.

Step 2: Boot by Using the Qumulo Core USB Drive Installer

1. When the node powers on and begins to boot, on the Supermicro screen, press F11.

Note

The boot setting is persistent: When you boot from a USB drive once, the node continues to boot from the USB drive. After you finish installing Qumulo Core, remove the USB drive from the node.

2. On the Please select boot device: screen, select your USB drive (usually labeled with **UEFI OS**) and boot into it.

Step 3: Install Qumulo Core

After the node reboots, the Field Verification Tool runs automatically.

Select **[1] Factory reset (DESTROYS ALL DATA)** and then enter **DESTROY ALL DATA**.

When the FVT finishes, the FVT passed! message appears.

Qumulo Core is now installed on your node.

Fixable Issues During Installation

If the FVT finds fixable issues, it prompts you to auto-correct any detected issues, depending on your installation scenario. Issues that the FVT can auto-correct include the following:

- BIOS Configuration

- Drive firmware
 - NIC mode
 - Boot order
1. To attempt auto-correction, select **[1] Run FVT Flash**. This will try to fix issues then reboot.
If the fixes are successful, the FVT reboots the node automatically.
 2. To re-attempt verification, [boot by using the Qumulo Core USB Drive Installer \(page 205\)](#) and then continue the installation.

Non-Fixable Issues

If the FVT is unable to auto-correct any issues, the message **Not fixable issues were detected** appears, providing reasons for failure.

For help with troubleshooting your node, [contact the Qumulo Care Team](#).

Step 4: Create and Configure Your Cluster

1. Review the **End User Agreement**, click **I agree to the End User Agreement**, and then click **Submit**.
2. Name your cluster.
3. On the **1. Set up cluster** page, select the nodes to add to your cluster.

As you select nodes, the installer updates the total capacity of your cluster at the bottom of the page.

i Note

If any nodes are missing, confirm that they are powered on and connected to the same network.

4. Confirm that the individual nodes have the expected capacity.
5. On the **2. Confirm cluster protection level** page, Qumulo Core selects the recommended 2, 3, or 4-drive protection level based on your cluster size and node type.
6. If the **Customize Protection Level** option appears, you can increase your system resilience by selecting 3- or 4-drive protection.

⚠ Important

- Qumulo Core 6.1.0.1 and 6.1.1 support Adaptive Data Protection by letting you reconfigure your cluster's fault tolerance level and storage efficiency only when you add nodes to your cluster.

Depending on your cluster, Qumulo Core shows configuration options that offer better fault tolerance levels, better storage efficiency, or both benefits. To enable Adaptive Data Protection for your cluster, you must [contact the Qumulo Care Team](#).

- In Qumulo Core 6.1.2 (and higher), you can change your cluster's data protection configuration when you add or replace nodes by using the `qq` CLI.
- Using 3- or 4-drive protection reduces the total capacity of your cluster.

7. Enter a password for the administrative account and click **Create Cluster**.
8. To access the Qumulo Core Web UI, connect to any node by entering its IP address into a browser.

Drive Bay Mapping in Supermicro A+ ASG-1014S-ACR12N4H Nodes

This section explains the drive bay mapping in Supermicro 1014S nodes.

⚠ Important

The Supermicro A+ WIO 1114S-WN10RT platform has reached its End of Life (EoL) on May 23, 2025. For more information about End of Platform Support (EoPS), contact [Supermicro support](#).

Your Supermicro 1014S chassis contains 12 HDDs, 4 NVMe drives, and one NVMe boot drive in an internal M.2 expansion slot. The following is the mapping for the drives.

HDD Drives



NVMe Drives

Front

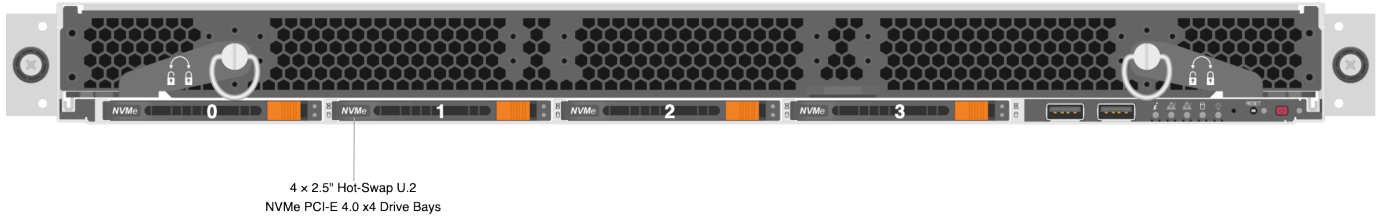

NVMe Boot Drive

The boot drive is located at the M.2-HC1 expansion slot. For information about the NVMe boot drive, see [Installing an M.2 Solid State Drive](#) in the Supermicro documentation.

Panel LEDs on Supermicro A+ ASG-1014S-ACR12N4H Nodes

This section explains the LEDs on Supermicro 1014S nodes.

⚠ Important

The Supermicro A+ WIO 1114S-WN10RT platform has reached its End of Life (EoL) on May 23, 2025. For more information about End of Platform Support (EoPS), contact [Supermicro support](#).

Front Panel LEDs and Buttons

On the front, right side of your node, there are five LEDs.

Label	Color and Behavior	Description
Info	● (solid red)	Node overheated
Info	● (1 s. blinking red)	Fan failed
Info	● (4 s. blinking red)	Power Supply Unit (PSU) failed
Info	● (solid blue)	Unit Identification (UID) activated locally
Info	● (blinking blue)	UID activated from IPMI
NIC 2 LED	● (solid green)	On
NIC 2 LED	● (blinking)	Network activity
NIC 1 LED	● (solid green)	On
NIC 1 LED	● (blinking)	Network activity
HDD LED	● (blinking)	Disk activity
Power LED	● (on)	On

NVMe Drive Carrier LEDs

Each NVMe drive carrier has two LEDs.

Label	Color or Behavior	Description
Status LED	Off	No issues detected
Status LED	● (solid red)	Drive failed
Status LED	● (1 s. blinking red)	Drive rebuild activity
Status LED	● (2 red blinks) then 1 s. stop	Hot spare drive
Status LED	● (5 s.) then off	Power-on drive status
Status LED	● (0.25 s. blinking red)	Identifying or locating drive status
Status LED	● (on)	Drive is safe to remove
Status LED	● (solid amber)	Drive isn't safe to remove
Activity LED	● (solid blue)	Drive installed
Activity LED	● (blinking blue)	Drive activity

Networking Your Supermicro A+ ASG-1014S-ACR12N4H Cluster

This section explains how to network a Supermicro 1014S cluster, lists the networking prerequisites, outlines the recommended configuration, and explains how to connect to redundant switches or to a single switch.

⚠ Important

The Supermicro A+ WIO 1114S-WN10RT platform has reached its End of Life (EoL) on May 23, 2025. For more information about End of Platform Support (EoPS), contact [Supermicro support](#).

✓ Tip

To identify the eth port, run the following command:

```
for i in /sys/class/net/eth*; \
do echo $i; \
cat $i/device/uevent | \
grep -i pci_slot; \
done
```

Prerequisites

📘 Note

Before you create your Qumulo cluster, if your client environment requires Jumbo Frames (9,000 MTU), configure your switch to support a higher MTU.

Your node requires the following resources.

- A network switch with the following specifications:
 - Ethernet connectivity
 - Fully non-blocking architecture
 - IPv6 capability
- Compatible networking cables
- A sufficient number of ports for connecting all nodes to the same switch fabric

- One static IP for each node, for each defined VLAN

Recommended Configuration

This platform uses a *unified networking configuration* in which the same NIC handles back-end and front-end traffic. In this configuration, each networking port provides communication with clients and between nodes. You can connect the NIC's ports to the same switch or to different switches. However, for greater reliability, we recommend connecting both ports on every node to each switch.

We recommend the following configuration for your node.

- Your Qumulo MTU configured to match your client environment
- Two physical connections for each node, one connection for each redundant switch
- One Link Aggregation Control Protocol (LACP) port-channel for each network on each node, with the following configuration
 - Active mode
 - Slow transmit rate
 - Access port or trunk port with a native VLAN
- DNS servers
- A Network Time Protocol (NTP) server
- Firewall protocols or ports allowed for proactive monitoring
- Where **N** is the number of nodes, **N-1** floating IP addresses for each node, for each client-facing VLAN

Connecting to Redundant Switches

For redundancy, we recommend connecting your cluster to dual switches. If either switch becomes inoperative, the cluster is still be accessible from the remaining switch.

- Connect the two NIC ports on your nodes to separate switches.
- The uplinks to the client network must equal the bandwidth from the cluster to the switch.
- The two ports form an LACP port channel by using a multi-chassis link aggregation group.
- Use an appropriate inter-switch link or virtual port channel.

Connecting to a Single Switch

You can connect a your cluster to a single switch. If this switch becomes inoperative, the entire cluster becomes inaccessible.

- Connect the two NIC ports on your nodes to a single switch.
- The uplinks to the client network must equal the bandwidth from the cluster to the switch.
- The two ports form an LACP port channel.

Four-Node Cluster Architecture Diagram

The following is the recommended configuration for a four-node cluster connected to an out-of-band management switch and redundant switches.

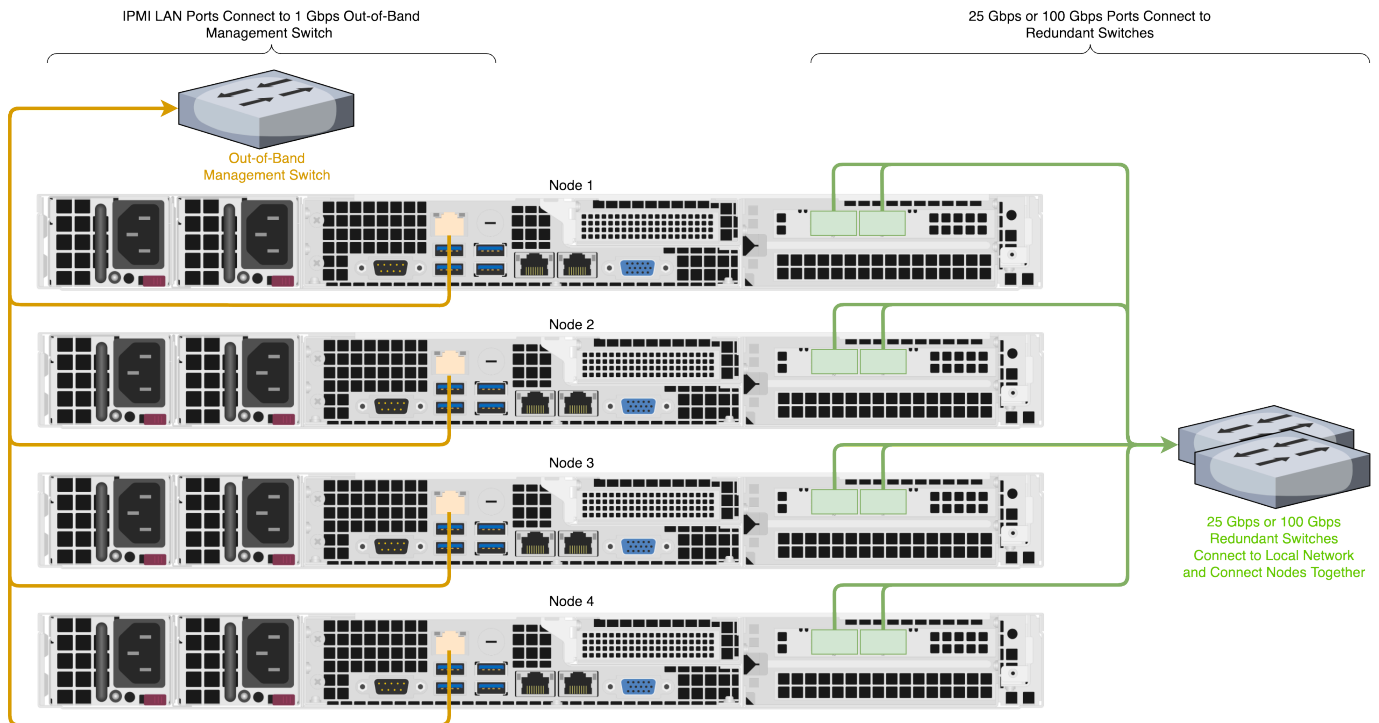

Replacing Hardware Components in Your Supermicro A+ ASG-1014S-ACR12N4H Nodes

This section explains how to replace hardware components in Supermicro 1014S nodes.

⚠ Important

The Supermicro A+ WIO 1114S-WN10RT platform has reached its End of Life (EoL) on May 23, 2025. For more information about End of Platform Support (EoPS), contact [Supermicro support](#).

⚠ Caution

- We strongly recommend engaging an on-site engineer to replace failed hardware components including but not limited to any procedure that:
 - This guide doesn't cover
 - You haven't received training on
 - Requires precautions to avoid damage caused by electrostatic discharge (ESD) by using industry standard anti-static equipment (such as gloves or wrist straps)
- We don't recommend updating firmware on Qumulo-certified hardware nodes unless the equipment manufacturer or a member of the Qumulo Care Team advises you to do so. For questions about this process, [contact the Qumulo Care Team](#).

To Perform the Part Replacement Procedure by Using the FVT

When you replace a component such as the motherboard or a NIC card in your node, you must ensure that the firmware version and configuration are correct for your new components. To do this, you must perform the part replacement procedure by using the FVT.

📘 Note

Before you replace the motherboard, you must request a new Data Center Management Suite (DCMS) license key from Supermicro and apply it before you run the FVT. (The license key uses the BMC MAC address which changes with the motherboard.) If you don't install a DCMS license on your node, the Field Verification Tool (FVT) fails, preventing you from running the part replacement procedure in the FVT, which normalizes the firmware and BIOS configuration for your new motherboard.

1. Boot by using the latest version of the Qumulo Core USB Drive Installer.

2. Select **[*] Perform maintenance**.
3. Select **[2] Perform automatic repair after part replacement (non-destructive)**.

The part replacement procedure runs and the **FVT passed!** message appears.

i Note

In some cases, after the part replacement procedure, the message **FIX: Run the FVT flash command.** appears. Enter 1 as you would for a fixable issue to reboot the node and then repeat the part replacement procedure.

Replacing a Drive

Your Supermicro 1014S chassis contains 12 HDDs, 4 NVMe drives, and one NVMe boot drive in an internal M.2 expansion slot. For information about replacing a drive, see [Drive Bay Mapping \(page 208\)](#) and the following topics in the Supermicro documentation.

- [Storage Drives \(HDD and NVMe\)](#)
- [Installing an M.2 Solid State Drive](#)

Initializing the Replacement Boot Drive

After you replace the boot drive, you must initialize the replacement boot drive by using the Qumulo Core Installer and then rebuild the replacement boot drive by using a script on the node in your cluster.

Step 1: Initialize the Replacement Boot Drive

✓ Tip

To get the correct version of the Qumulo Core Installer for the node in your cluster, [contact the Qumulo Care Team](#)

1. [Create a Qumulo Core USB Drive Installer \(page 10\)](#).
2. Power on your node, enter the boot menu, and select your USB drive.

The Qumulo Core Installer begins to run automatically.

3. When prompted, take the following steps:
 - a. Select **[x] Perform maintenance**.
 - b. Select **[1] Boot drive reset** and then follow the prompts.

The Qumulo Core Installer initializes the boot drive.

4. When the process is complete, the node is powered down automatically.

Step 2: Rebuild the Replacement Boot Drive

1. Power on your node and log in to the node by using the `qq` CLI.
2. To get `root` privileges, run the `sudo qsh` command.
3. To stop the Qumulo Networking Services, run the `service qumulo-networking stop` command.
4. To configure the IP address for the node, run the `ip addr add` command and specify the node's IP address. For example:

```
ip addr add 203.0.113.0/CDR dev bond0
```

5. Ensure that the node can ping other nodes in the cluster.
6. Run the `rebuild_boot_drive.py` script and specify the IP address of *another node* in the cluster, the ID of the node whose boot drive has been replaced, and the password of the administrative account of the cluster. For example:

Note

If your password includes special characters such as the parenthesis (`()`) or the asterisk (`*`), use the backslash (`\`) to escape these characters.

```
/opt/qumulo/rebuild_boot_drive.py \  
  --address 203.0.113.1 \  
  --node-id 2 \  
  --username admin \  
  --password my\ (Special\ *Password
```

Follow the prompts.

7. When the process is complete, reboot the node.

Replacing a Power Supply Unit (PSU)

Your Supermicro 1014S chassis contains two PSUs. For information about replacing a PSU, see [Power Supply](#) in the Supermicro documentation.

Replacing a Fan

Your Supermicro 1014S chassis has six internal fans. For information about replacing a fan, see [System Fans](#) in the Supermicro documentation.

Replacing a DIMM

Your Supermicro 1014S chassis has 16 DIMM slots. For information about replacing a DIMM, see [DIMM Installation](#) and [DIMM Module Population](#) in the Supermicro documentation.

i Note

To identify which DIMM failed, you must use the baseboard management controller (BMC) on the node or another hardware monitoring solution.

Supermicro A+ WIO 1114S-WN10RT

Racking Your Supermicro A+ WIO 1114S-WN10RT Nodes

This section describes how to use the outside and inside rails of Supermicro 1114S nodes and how to rack nodes in a data center.

⚠ Important

The Supermicro A+ WIO 1114S-WN10RT platform has reached its End of Life (EoL) on April 18, 2025. For more information about End of Platform Support (EoPS), contact [Supermicro support](#).

To Attach the Outer and Inner Rails

📘 Note

- Because the left and right rails of your nodes are identical, the words **FRONT** and **BACK** might appear upside down.
- Each *outer rail* comes as two connected pieces and attaches to your server rack.
- Each *inner rail* comes as two separate pieces and attaches to the node chassis.

1. Adjust the outer rails to the length of your server rack.
2. Line up the edge of the outer rail between the rack unit (RU) markers, insert the tabs on the edge of the rail into the mounting holes, and push the rail into the rack until the quick-release clicks into place. This process is the same for the front and back of your rack.



3. Snap the inner rails to the chassis and secure them by using two screws on each side, near the middle of the chassis.

Note

First attach the front inner rails, then the back inner rails.



To Insert the Chassis

1. Align the outer and inner rails and insert the chassis into the server rack.
2. Attach the chassis to the rack by using one screw on each side, on the front of the chassis.

To Remove the Chassis

1. Disconnect any cables from the chassis.
2. Remove one screw from each side of the front of the chassis.
3. Pull the chassis out from the server rack partially. When the first set of black snaps appears, pinch the long piece of the snap towards the short one (up on one side, down on the other).

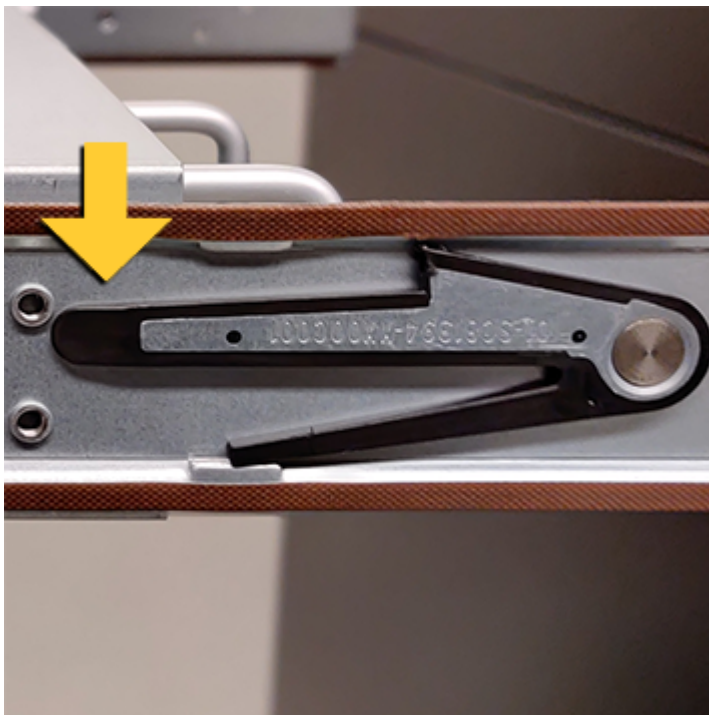

4. Continue to pull the chassis from the server rack. When the second set of black snaps appears, pinch the long piece of each snap towards the short one (up on one side, down on the other) and remove the chassis completely.

Configuring the Intelligent Platform Management Interface (IPMI) and Wiring Your Supermicro A+ WIO 1114S-WN10RT Nodes

This section explains how to wire the out-of-band management (IPMI) port, 100 Gbps ports, and power on Supermicro 1114S nodes.

⚠ Important

The Supermicro A+ WIO 1114S-WN10RT platform has reached its End of Life (EoL) on April 18, 2025. For more information about End of Platform Support (EoPS), contact [Supermicro support](#).

This platform uses a *split networking configuration* in which different NICs handle back-end and front-end traffic. You can connect the front-end and back-end NICs to the same switch or to different switches.

📘 Note

The two rightmost Ethernet ports on the back of your node are unused.

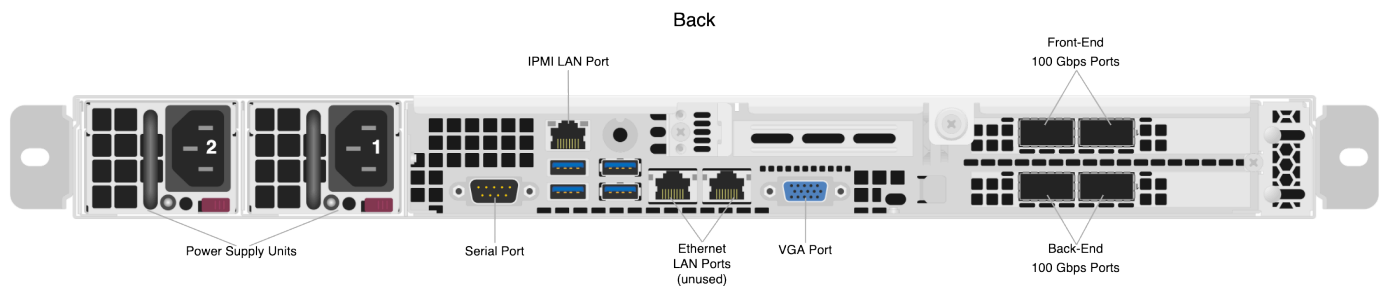

How the IPMI Port Works

The dedicated out-of-band management port allows functionality such as remote display, control, and power. The port uses the Intelligent Platform Management Interface (IPMI) protocol.

The IPMI port is located on the back of your node. For more information, see the documentation from your hardware vendor.

For more information, see [Default IPMI Usernames and Passwords](#)  on Qumulo Care.

📘 Note

The IPMI username and password are unrelated to your Qumulo administrative credentials.

To configure the IPMI port, you must use the IPMI Management Utility installed on the motherboard. For more information, see [Supermicro BMC User Guide X12](#).

Step 2: Connecting the 100 Gbps Ports

After you connect the IPMI port, connect your front-end and back-end 100 Gbps ports (compatible with QSFP28 and QSFP56). There are four 100 Gbps ports on the back of your node. To maximize redundancy, split interfaces across subnets by connecting each port to a different switch.

✓ Tip

To identify the eth port, run the following command:

```
for i in /sys/class/net/eth*; \  
do echo $i; \  
cat $i/device/uevent | \  
grep -i pci_slot; \  
done
```

Step 3: Connecting the Power

After you connect your 100 Gbps ports, connect power to the node. There are two power sockets on the back of your node. To maximize redundancy, connect each PSU to a separate power supply or power distribution unit (PDU).

Creating and Configuring a Qumulo Cluster with Supermicro A+ WIO 1114S-WN10RT Nodes

This section explains how to prepare Supermicro 1114S nodes for creating a Qumulo cluster.

Important

The Supermicro A+ WIO 1114S-WN10RT platform has reached its End of Life (EoL) on April 18, 2025. For more information about End of Platform Support (EoPS), contact [Supermicro support](#).

Step 1: Verify Your Node

1. Shut down your node and connect a display, a keyboard, and a mouse to it.
2. Plug the [Qumulo Core USB Drive Installer](#) into an available USB port on the node and then press the power button.

Step 2: Boot by Using the Qumulo Core USB Drive Installer

1. When the node powers on and begins to boot, on the Supermicro screen, press F11.

Note

The boot setting is persistent: When you boot from a USB drive once, the node continues to boot from the USB drive. After you finish installing Qumulo Core, remove the USB drive from the node.

2. On the **Please select boot device:** screen, select your USB drive (usually labeled with **UEFI OS**) and boot into it.

Step 3: Install Qumulo Core

After the node reboots, the Field Verification Tool runs automatically.

Select **[1] Factory reset (DESTROYS ALL DATA)** and then enter **DESTROY ALL DATA**.

When the FVT finishes, the **FVT passed!** message appears.

Qumulo Core is now installed on your node.

Fixable Issues During Installation

If the FVT finds fixable issues, it prompts you to auto-correct any detected issues, depending on your installation scenario. Issues that the FVT can auto-correct include the following:

- BIOS Configuration

- Drive firmware
 - NIC mode
 - Boot order
1. To attempt auto-correction, select **[1] Run FVT Flash**. This will try to fix issues then reboot. If the fixes are successful, the FVT reboots the node automatically.
 2. To re-attempt verification, [boot by using the Qumulo Core USB Drive Installer \(page 224\)](#) and then continue the installation.

Non-Fixable Issues

If the FVT is unable to auto-correct any issues, the message **Not fixable issues were detected** appears, providing reasons for failure.

For help with troubleshooting your node, [contact the Qumulo Care Team](#).

Step 4: Create and Configure Your Cluster

1. Review the **End User Agreement**, click **I agree to the End User Agreement**, and then click **Submit**.
2. Name your cluster.
3. On the **1. Set up cluster** page, select the nodes to add to your cluster.

As you select nodes, the installer updates the total capacity of your cluster at the bottom of the page.

i Note

If any nodes are missing, confirm that they are powered on and connected to the same network.

4. Confirm that the individual nodes have the expected capacity.
5. On the **2. Confirm cluster protection level** page, Qumulo Core selects the recommended 2, 3, or 4-drive protection level based on your cluster size and node type.
6. If the **Customize Protection Level** option appears, you can increase your system resilience by selecting 3- or 4-drive protection.

⚠ Important

- Qumulo Core 6.1.0.1 and 6.1.1 support Adaptive Data Protection by letting you reconfigure your cluster's fault tolerance level and storage efficiency only when you add nodes to your cluster.

Depending on your cluster, Qumulo Core shows configuration options that offer better fault tolerance levels, better storage efficiency, or both benefits. To enable Adaptive Data Protection for your cluster, you must [contact the Qumulo Care Team](#).

- In Qumulo Core 6.1.2 (and higher), you can change your cluster's data protection configuration when you add or replace nodes by using the `qq` CLI.
- Using 3- or 4-drive protection reduces the total capacity of your cluster.

7. Enter a password for the administrative account and click **Create Cluster**.
8. To access the Qumulo Core Web UI, connect to any node by entering its IP address into a browser.

Drive Bay Mapping in Supermicro A+ WIO 1114S-WN10RT Nodes

This section explains the drive bay mapping in Supermicro 1114S nodes.

⚠ Important

The Supermicro A+ WIO 1114S-WN10RT platform has reached its End of Life (EoL) on April 18, 2025. For more information about End of Platform Support (EoPS), contact [Supermicro support](#).

Your node contains bays for 10 drives and one boot drive in an internal M.2 expansion slot. The following is the mapping for the drives.

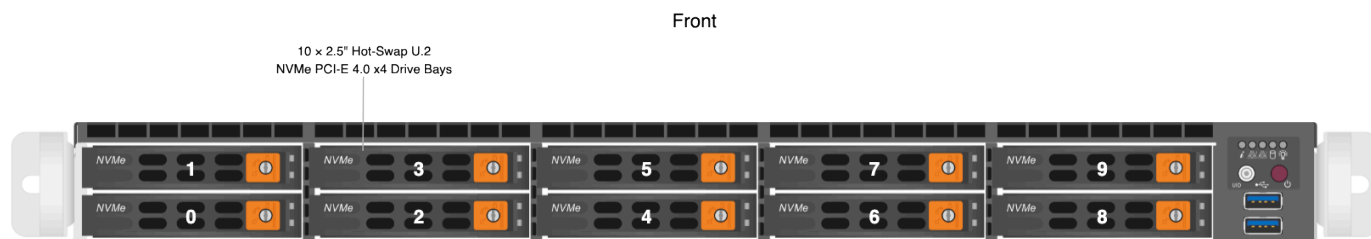

Panel LEDs on Supermicro A+ WIO 1114S-WN10RT Nodes







This section explains the LEDs on Supermicro 1114S nodes.

Important

The Supermicro A+ WIO 1114S-WN10RT platform has reached its End of Life (EoL) on April 18, 2025. For more information about End of Platform Support (EoPS), contact [Supermicro support](#).

Front Panel LEDs and Buttons

On the front, right side of your node, there are five LEDs.

Label	Color and Behavior	Description
Info	 (solid red)	Node overheated
Info	 (1 s. blinking red)	Fan failed
Info	 (4 s. blinking red)	Power Supply Unit (PSU) failed
Info	 (solid blue)	Unit Identification (UID) activated locally
Info	 (blinking blue)	UID activated from IPMI
Lan A	Off	Unused
Lan B	Off	Unused
Disk Activity	 (solid yellow)	On or blinking
Power	 (solid green)	On

Note

During normal operation, the Lan B LED might appear to be lit slightly when the Disk Activity LED is on.

Networking Your Supermicro A+ WIO 1114S-WN10RT Cluster

This section explains how to network a Supermicro 1114S cluster, lists the networking prerequisites, outlines the recommended configuration, and explains how to connect to redundant switches or to a single switch.

⚠ Important

The Supermicro A+ WIO 1114S-WN10RT platform has reached its End of Life (EoL) on April 18, 2025. For more information about End of Platform Support (EoPS), contact [Supermicro support](#).

✓ Tip

To identify the eth port, run the following command:

```
for i in /sys/class/net/eth*; \
do echo $i; \
cat $i/device/uevent | \
grep -i pci_slot; \
done
```

Prerequisites

📘 Note

Before you create your Qumulo cluster, if your client environment requires Jumbo Frames (9,000 MTU), configure your switch to support a higher MTU.

Your node requires the following resources.

- A network switch with the following specifications:
 - Ethernet connectivity
 - Fully non-blocking architecture
 - IPv6 capability
- Compatible networking cables
- A sufficient number of ports for connecting all nodes to the same switch fabric

- One static IP for each node, for each defined VLAN

Recommended Configuration

This platform uses a *unified networking configuration* in which the same NIC handles back-end and front-end traffic. In this configuration, each networking port provides communication with clients and between nodes. You can connect the NIC's ports to the same switch or to different switches. However, for greater reliability, we recommend connecting both ports on every node to each switch.

We recommend the following configuration for your node.

- Your Qumulo MTU configured to match your client environment
- Two physical connections for each node, one connection for each redundant switch
- One Link Aggregation Control Protocol (LACP) port-channel for each network on each node, with the following configuration
 - Active mode
 - Slow transmit rate
 - Access port or trunk port with a native VLAN
- DNS servers
- A Network Time Protocol (NTP) server
- Firewall protocols or ports allowed for proactive monitoring
- Where **N** is the number of nodes, **N-1** floating IP addresses for each node, for each client-facing VLAN

Connecting to Redundant Switches

For redundancy, we recommend connecting your cluster to dual switches. If either switch becomes inoperative, the cluster is still be accessible from the remaining switch.

- Connect the two NIC ports on your nodes to separate switches.
- The uplinks to the client network must equal the bandwidth from the cluster to the switch.
- The two ports form an LACP port channel by using a multi-chassis link aggregation group.
- Use an appropriate inter-switch link or virtual port channel.

Connecting to a Single Switch

You can connect a your cluster to a single switch. If this switch becomes inoperative, the entire cluster becomes inaccessible.

- Connect the two NIC ports on your nodes to a single switch.
- The uplinks to the client network must equal the bandwidth from the cluster to the switch.
- The two ports form an LACP port channel.

Four-Node Cluster Architecture Diagram

The following is the recommended configuration for a four-node cluster connected to an out-of-band management switch and redundant switches.

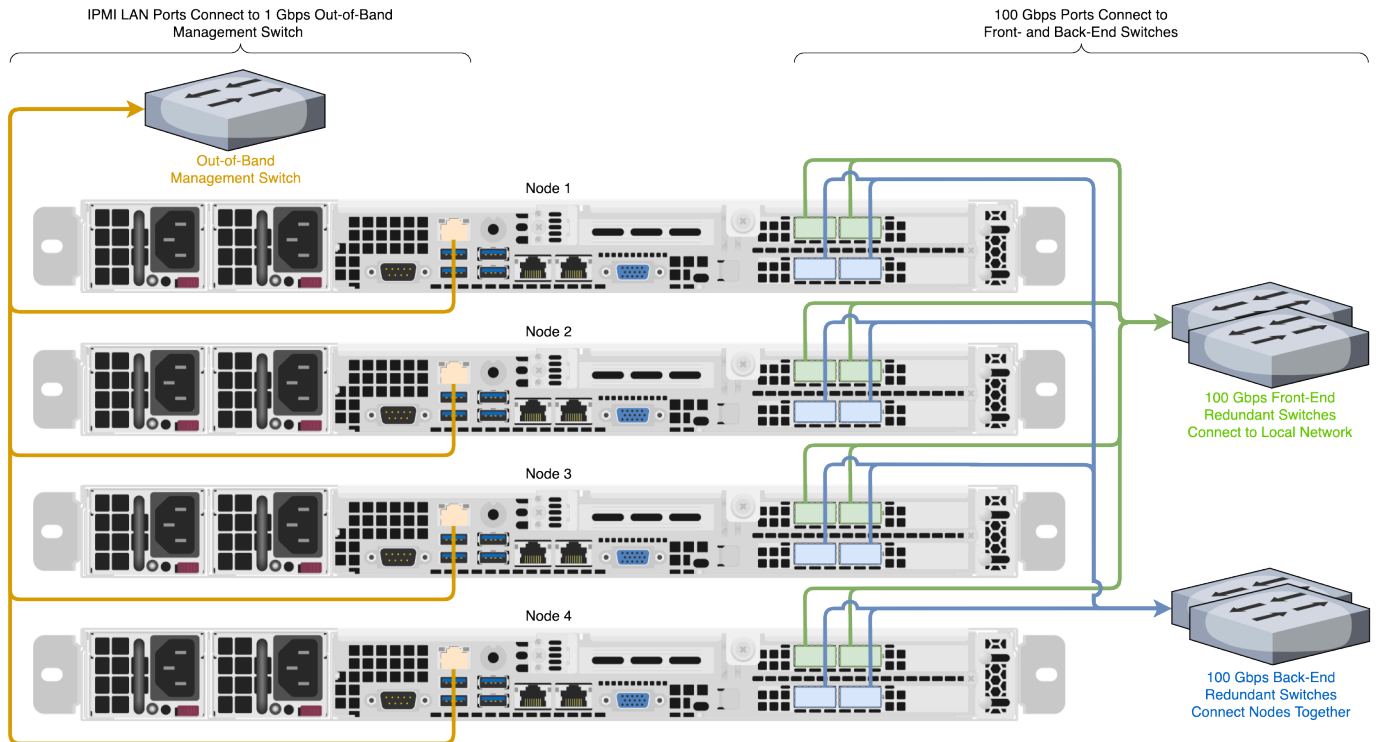

Replacing Hardware Components in Your Supermicro A+ WIO 1114S-WN10RT Nodes

This section explains how to replace hardware components in Supermicro 1114S nodes.

⚠ Important

The Supermicro A+ WIO 1114S-WN10RT platform has reached its End of Life (EoL) on April 18, 2025. For more information about End of Platform Support (EoPS), contact [Supermicro support](#).

⚠ Caution

- We strongly recommend engaging an on-site engineer to replace failed hardware components including but not limited to any procedure that:
 - This guide doesn't cover
 - You haven't received training on
 - Requires precautions to avoid damage caused by electrostatic discharge (ESD) by using industry standard anti-static equipment (such as gloves or wrist straps)
- We don't recommend updating firmware on Qumulo-certified hardware nodes unless the equipment manufacturer or a member of the Qumulo Care Team advises you to do so. For questions about this process, [contact the Qumulo Care Team](#).

To Perform the Part Replacement Procedure by Using the FVT

When you replace a component such as the motherboard or a NIC card in your node, you must ensure that the firmware version and configuration are correct for your new components. To do this, you must perform the part replacement procedure by using the FVT.

ℹ Note

Before you replace the motherboard, you must request a new Data Center Management Suite (DCMS) license key from Supermicro and apply it before you run the FVT. (The license key uses the BMC MAC address which changes with the motherboard.) If you don't install a DCMS license on your node, the Field Verification Tool (FVT) fails, preventing you from running the part replacement procedure in the FVT, which normalizes the firmware and BIOS configuration for your new motherboard.

1. Boot by using the latest version of the Qumulo Core USB Drive Installer.

2. Select [*] Perform maintenance.
3. Select [2] Perform automatic repair after part replacement (non-destructive).

The part replacement procedure runs and the FVT passed! message appears.

Note

In some cases, after the part replacement procedure, the message `FIX: Run the FVT flash command.` appears. Enter 1 as you would for a fixable issue to reboot the node and then repeat the part replacement procedure.

To Replace a Drive

The ten hot-swap drive carriers are located at the front of your Supermicro 1114S chassis.

Replacement drives, including the on-site spare drives that you received with your original nodes, are provided without a drive carrier. When replacing a faulty drive, you must remove the existing drive from its carrier and then insert the new drive into the carriers. The drive carriers are toolless and don't require any screws.

Caution

We strongly recommend having a Supermicro engineer perform on-site boot drive replacement.

1. Locate the drive that requires replacement by using the drive bay mapping.

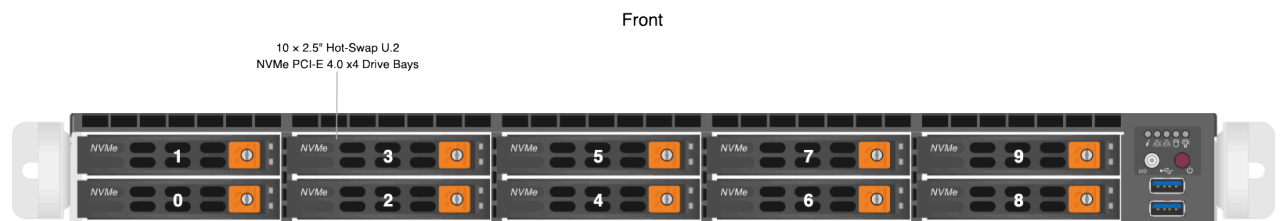

2. To remove the existing drive:
 - a. Press the orange release button on the right of the drive carrier until the drive carrier handle extends on the left.
 - b. Use the drive carrier handle to pull the carrier out of the chassis.
 - c. To remove the drive from the carrier, undo the mounting clips.
3. To install a replacement drive:
 - a. Insert the new drive into the drive carrier with the printed circuit board (PCB) side facing down and the connector end facing towards the rear of the tray.

- b. Secure the drive to its carrier by using the mounting clips.
- c. Insert the drive carrier into the chassis with the orange release button facing right.
- d. Push the drive carrier into the chassis until the handle retracts and clicks into place.

Note

If you remove and reinsert a drive extremely quickly (faster than one second), the baseboard management controller (BMC) doesn't recognize the drive and the activity LEDs don't return to their normal states. To resolve this issue, remove the drive, wait five seconds, and then reinsert it.

Initializing the Replacement Boot Drive

After you replace the boot drive, you must initialize the replacement boot drive by using the Qumulo Core Installer and then rebuild the replacement boot drive by using a script on the node in your cluster.

Step 1: Initialize the Replacement Boot Drive

Tip

To get the correct version of the Qumulo Core Installer for the node in your cluster, [contact the Qumulo Care Team](#)

1. [Create a Qumulo Core USB Drive Installer \(page 10\)](#).
2. Power on your node, enter the boot menu, and select your USB drive.

The Qumulo Core Installer begins to run automatically.

3. When prompted, take the following steps:
 - a. Select `[x] Perform maintenance`.
 - b. Select `[1] Boot drive reset` and then follow the prompts.

The Qumulo Core Installer initializes the boot drive.

4. When the process is complete, the node is powered down automatically.

Step 2: Rebuild the Replacement Boot Drive

1. Power on your node and log in to the node by using the `qq` CLI.
2. To get `root` privileges, run the `sudo qsh` command.
3. To stop the Qumulo Networking Services, run the `service qumulo-networking stop` command.

4. To configure the IP address for the node, run the `ip addr add` command and specify the node's IP address. For example:

```
ip addr add 203.0.113.0/CDR dev bond0
```

5. Ensure that the node can ping other nodes in the cluster.
6. Run the `rebuild_boot_drive.py` script and specify the IP address of *another node* in the cluster, the ID of the node whose boot drive has been replaced, and the password of the administrative account of the cluster. For example:

Note

If your password includes special characters such as the parenthesis (()) or the asterisk (*), use the backslash (\) to escape these characters.

```
/opt/qumulo/rebuild_boot_drive.py \  
  --address 203.0.113.1 \  
  --node-id 2 \  
  --username admin \  
  --password my\ (Special\ *Password
```

Follow the prompts.

7. When the process is complete, reboot the node.

To Replace a Power Supply Unit (PSU)

The two hot-swap PSUs are located at the front of your Supermicro 1114S chassis. If either of the two PSUs fails, the other PSU takes on the full load and lets the node continue operating without interruption.

When a PSU fails, the Info LED at the front of the node begins to blink red every four seconds. In addition, the failure LED on the PSU at the back of the node lights up.

1. To determine which PSU failed, check the PSU LED.

Back

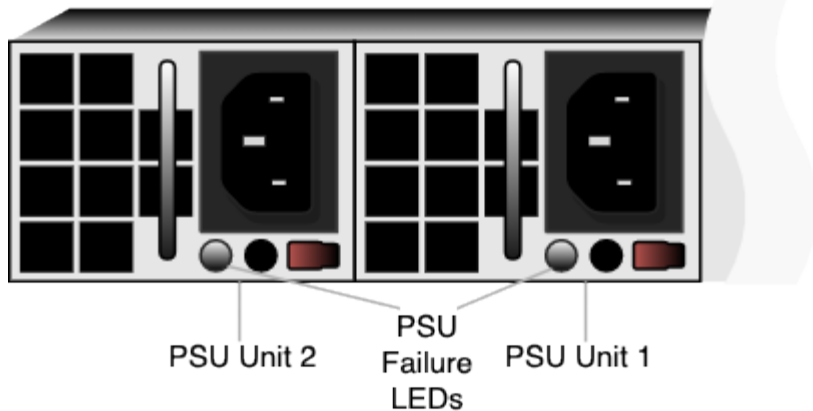

2. Disconnect the power cord from the existing PSU.
3. To remove the existing PSU, press the purple release tab to the left while pulling on the handle.
4. Insert the new PSU and push it into the chassis until it clicks into place.
5. Connect the power cord to the new PSU.

To Replace a Fan

Your Supermicro 1114S chassis has six internal fans. When a fan fails, the Info LED at the front of the node begins to blink red every second.

⚠ Caution

- The fans aren't hot-swappable. You must power off the node to replace a fan. However, you may remove the top cover to determine which fan failed.
- For optimal air circulation, you must always reinstall the top chassis cover. You must never run the node for an extended period of time with the top chassis cover removed.

1. Power off the node, remove the top chassis cover, and disconnect the power cords from both PSUs.
2. Disconnect the existing fan housing cable from the motherboard and remove the fan housing from its two mounting posts.
3. Insert a new fan provided by Supermicro into the housing, making sure that the airflow direction arrows on top of the fan face the same direction as the arrows on the other fans.

4. Reposition the fan housing over the two mounting posts and connect the fan housing cable to the motherboard.
5. Power on the node and confirm that the new fan is working properly and the Info LED has stopped blinking red.
6. Install the top chassis cover.

To Replace a DIMM

Your Supermicro 1114S chassis has 16 DIMM slots (8 × 16 GB DIMMs for a total 128 GB of memory).

To identify which DIMM failed, you must use the baseboard management controller (BMC) on the node or another hardware monitoring solution.

! Caution

- Use extreme caution when handling DIMMs. Don't touch their metal contacts.
- Never force a DIMM into a slot. Each DIMM has a keyed notch which lets you insert the module in only one way.
- DIMMs aren't hot-swappable. You must power off the node to replace a DIMM.
- For optimal air circulation, you must always reinstall the top chassis cover. You must never run the node for an extended period of time with the top chassis cover removed.

1. Power off the node, remove the top chassis cover, and disconnect the power cords from both PSUs.
2. Remove the existing DIMM.

The following is the DIMM slot mapping. In this diagram, the CPU socket mounting bracket and power headers are at the bottom.

Slot	1	2	3	4	5	6	7	8	CPU Socket	9	10	11	12	13	14	15	16
DIMM	D2	D1	C2	C1	B2	B1	A2	A1	Bracket at bottom	E1	E2	F1	F2	G1	G2	H1	H2

3. To remove the existing DIMM, press both DIMM slot release tabs outwards. When the module is loose, remove it from the slot.
4. To insert a new DIMM, align the keyed notch on the DIMM with the receptive points on the DIMM slot.

5. Push in both ends of the DIMM straight down until it clicks into place.
6. Press both DIMM slot release tabs inwards.
7. Install the top chassis cover.
8. Power on the node.

Supermicro A+ WIO 1114S-WN10RT Technical Specifications

This section provides technical specifications for Supermicro 1114S node types.

⚠ Important

The Supermicro A+ WIO 1114S-WN10RT platform has reached its End of Life (EoL) on April 18, 2025. For more information about End of Platform Support (EoPS), contact [Supermicro support](#).

	Supermicro A+ WIO 1114S-WN10RT 153TB	Supermicro A+ WIO 1114S-WN10RT 76TB	Supermicro A+ WIO 1114S-WN10RT 30TB
Raw Capacity	153 TB	76 TB	30 TB
NVMe Drives	10 × 15.36 TB	10 × 10.78 TB	8 × 3.84 TB
Connectivity Ports	4 × 100 GbE		
CPU	1 × AMD EPYC 7402P or 7443 P 2.8 GHz, 24 Cores		
Memory	128 GB		
Physical Dimensions	1.7" (4.32 cm) × 17.2" (43.7 cm) × 23.5" (59.69 cm)		